



J360

EN 14439
C25

GRUA TORRE / TOWER CRANE
GRUE A TOUR / TURMDREHKRAN / БАШЕННЫЙ КРАН / رافعة برجية

FEM 1005 - C25

UNE-EN-ISO 9001

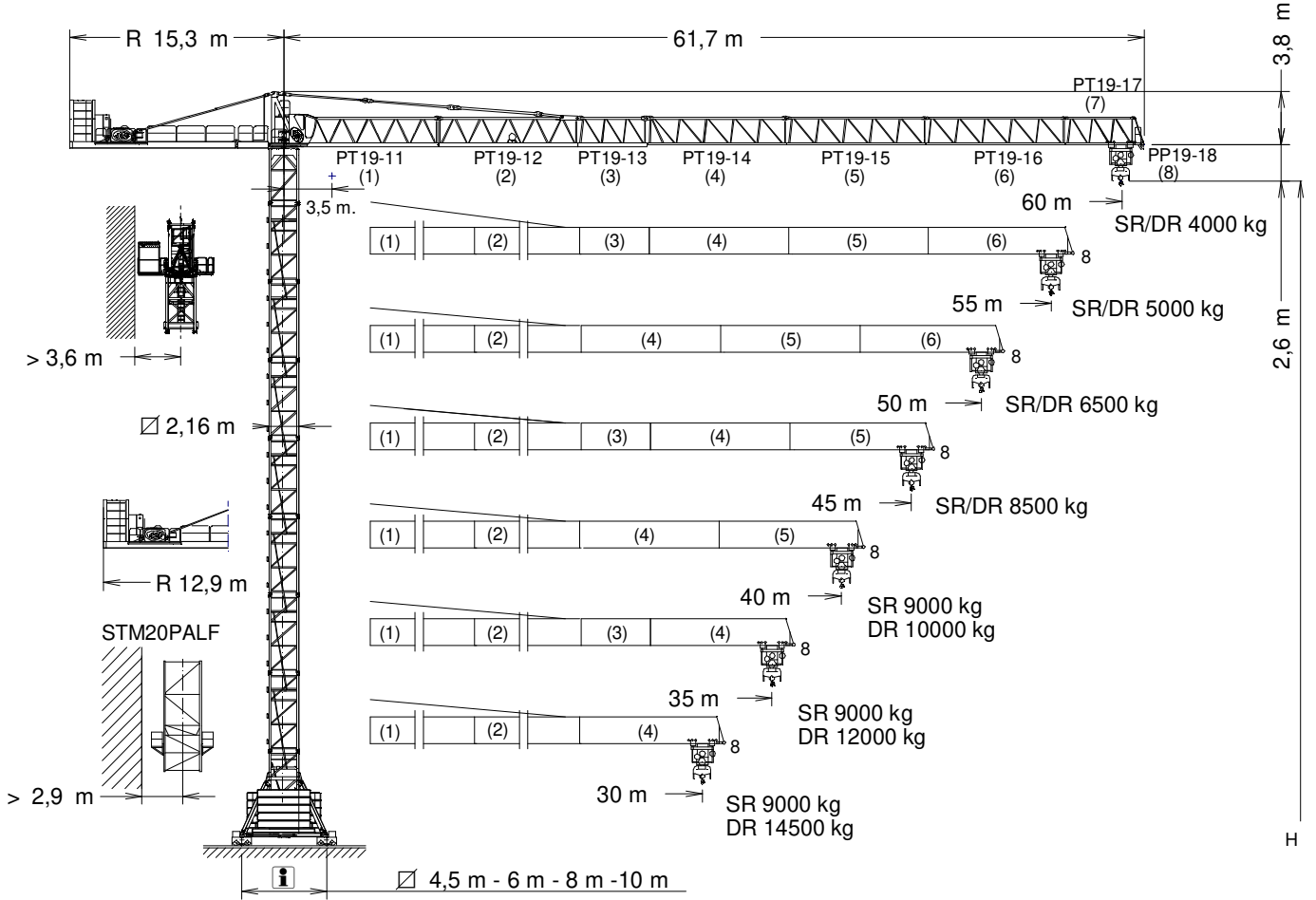

H= **Altura máxima bajo gancho sin arriostrar (m).** / **Maximum height under hook without fastening (m).** / **Hauteur maximale sous crochet sans ancrage (m).**
Max. Hakenhöhe ohne Verstreben (m). / Максимальная высота под крюком без крепления (m). / أقصى ارتفاع تحت الخطاف بدون ربط (m)

PT19-11.....166.40.000	PT19-16.....166.45.000	TL20-5,6.....204.31.400	TSR20-5,6.....206.31.000
PT19-12.....166.41.000	PT19-17.....166.46.000	TS20-5,6A.....204.31.500	TR24/TS20.....156.36.400
PT19-13.....166.42.000	PP19-18.....166.47.000	TS20-5,6.....204.31.200	TR24-5,6.....156.30.700
PT19-14.....166.43.000	TL20.....153.31.000	TSR20-5,6A.....206.31.300	TRD24-5,6.....163.31.300
PT19-15.....166.44.000			

CUSTOMIZE YOUR CRANE

OPTIMUS
line



OPTI Cube



TC Diagnosis SYSTEM



CLIMBING Solution



SAFETY Pack



Customization



ECO Mode



COMFORT Cabin



HIGH POWER Motors



JL25 Tower Crane Elevator



BE SMART keep control



Reservado el derecho a modificaciones sin previo aviso. Declinamos toda responsabilidad derivada de la información proporcionada / Subject to modification, without prior notice. This information is supplied without liability / L'entreprise se réserve le droit de procéder à des modifications sans préavis. Nous déclinons toute responsabilité quant aux informations fournies / Das Recht auf Änderungen ohne vorherige Ankündigung bleibt vorbehalten. Wir übernehmen keine Gewähr für die gemachten Angaben / Мы оставляем за собой право на внесение изменений без предварительного уведомления. Мы снимаем с себя любую ответственность в отношении предоставленной информации / حقوق التغيير محفوظة دون إشعار مسبق دون أدنى مسؤولية عن المعلومات المقدمة

29/11/2024

(H) ESTACIONARIA 1 / STATIONARY 1 / STATIONAIRE 1 / STATIONÄR 1 / СТАЦИОНАРНОЕ СОСТОЯНИЕ / ثابتة

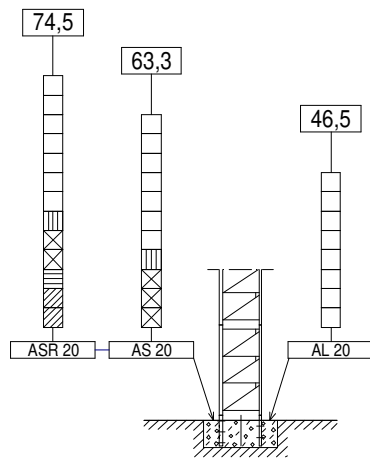

- TL20
- TL20-5,6
- TS20-5,6A
- TS20-5,6
- TSR20-5,6A
- TSR20-5,6
- TR24/TS20
- TR24-5,6

(H) ESTACIONARIA 3 / STATIONARY 3 / STATIONAIRE 3 / STATIONÄR 3 / СТАЦИОНАРНОЕ СОСТОЯНИЕ / ثابتة

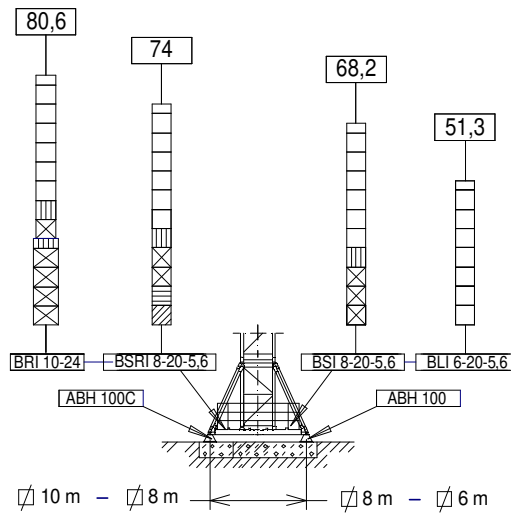

- TL20
- TL20-5,6
- TS20-5,6A
- TS20-5,6
- TSR20-5,6A
- TSR20-5,6
- TR24/TS20
- TR24-5,6

(H) TRASLACIÓN / TRAVELLING / TRASLATION / FORTBEWEGUNG / ПЕРЕМЕЩЕНИЕ / متحركة

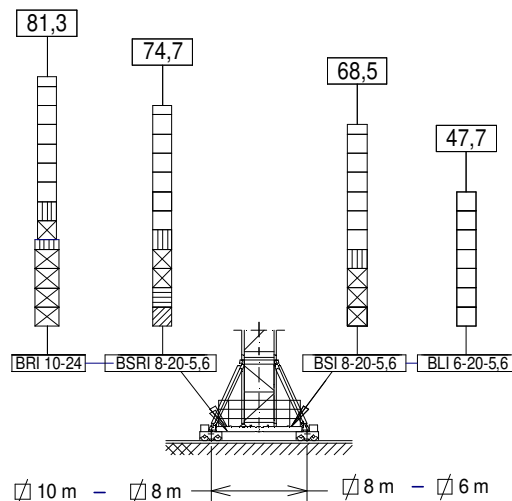



- TL20
- TL20-5,6
- TS20-5,6A
- TS20-5,6
- TSR20-5,6A
- TSR20-5,6
- TR24/TS20
- TR24-5,6

BLI 6-20-5,6 211.20.500
BSI 8-20-5,6 211.20.000

BSRI 8-20-5,6 204.20.000
BRI 10-24 156.20.500

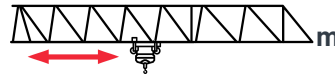
ABH 100 201.23.000
ABH 100C 170.23.000



	9 t 18 t @ ... (m)	15	20	25	30	35	40	45	50	55	60
60	31,1/16,7	9/18	9/14,76	9/11,53	9/9,38	7,84	6,69	5,79	5,08	4,49	4
55	33,8/18,1	9/18	9/16,16	9/12,66	9/10,32	8,65	7,39	6,42	5,64	5	—
50	38,0/20,3	9/18	9/18	9/14,38	9/11,75	9/9,88	8,47	7,38	6,5	—	—
45	42,8/22,9	9/18	9/18	9/16,4	9/13,44	9/11,32	9/9,73	8,5	—	—	—
40	40,0/23,5	9/18	9/18	9/16,83	9/13,79	9/11,63	9/10	—	—	—	—
35	35,0/24,2	9/18	9/18	9/17,35	9/14,23	9/12	—	—	—	—	—
30	30,0/24,6	9/18	9/18	9/17,68	9/14,5	—	—	—	—	—	—

Datos válidos para / Valid data for
Donnees valables pour / Gultige Daten für / Допустимые данные для / البيانات الصالحة لـ

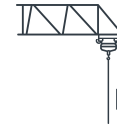

H ≤ 90 m

CARACTERÍSTICAS DE MECANISMOS / MECHANISMS FEATURES

CARACTÉRISTIQUES DES MÉCANISMES / MERKMALE DER MECHANISMEN
 ХАРАКТЕРИСТИКИ МЕХАНИЗМОВ / الخصائص الآلية

J360

***EC60100VF**
45 kW



EC88145VF
65 kW

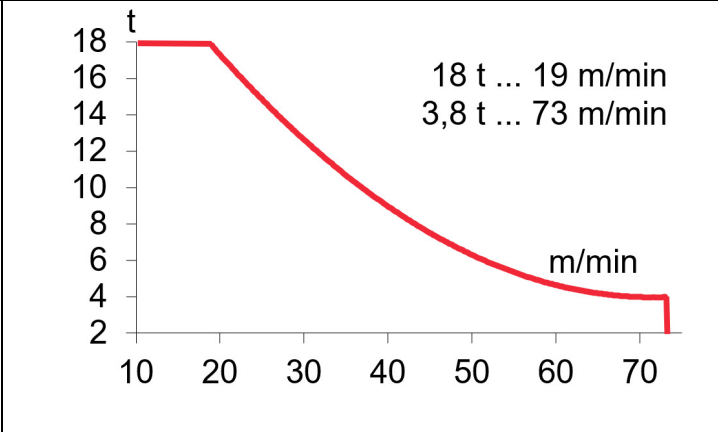
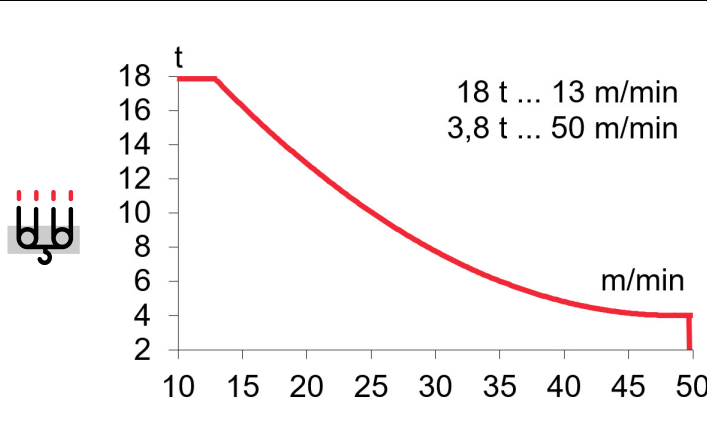
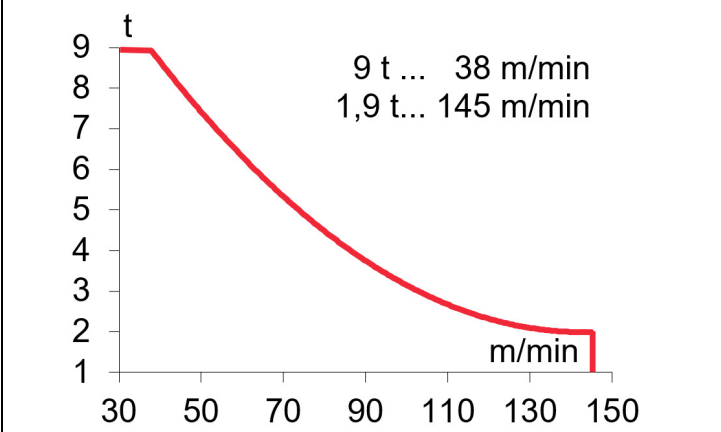
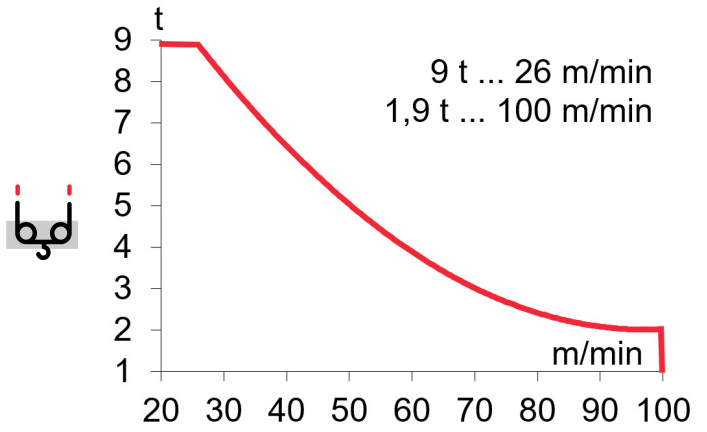

$H \leq$ SR 328 m
DR 164 m

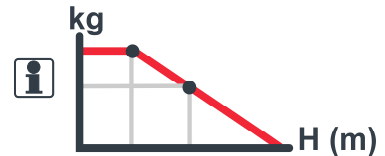

 OG2208VF 3 x 5,5 kW	 TC760VF 5,5 kW	 TG4025VF 4 x 7,5 kW	 TH2006 15 kW
0...0,8 r/min sl/min	9 t 0...60 m/min 18 t 0...30 m/min	0...25 m/min	0,6 m/min

3~ 400V 50Hz
480V 60Hz

KVA			
EC60100VF	52	65	78
EC88145VF	58	74	89

FEM 1005 - C25

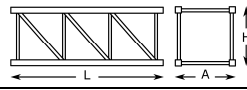
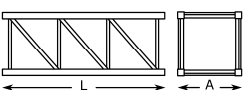
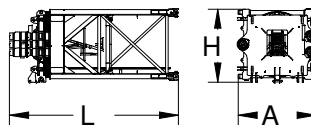
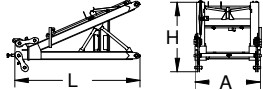
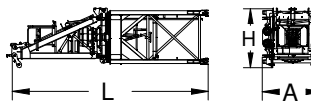
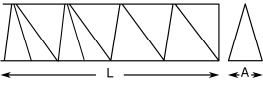
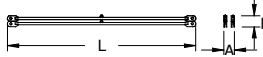
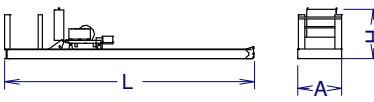
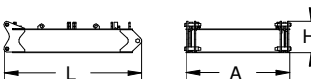
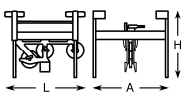
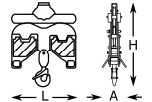

Reservado el derecho a modificaciones sin previo aviso. Declinamos toda responsabilidad derivada de la información proporcionada / Subject to modification, without prior notice. This information is supplied without liability / L'entreprise se réserve le droit de procéder à des modifications sans préavis. Nous déclinons toute responsabilité quant aux informations fournies / Das Recht auf Änderungen ohne vorherige Ankündigung bleibt vorbehalten. Wir übernehmen keine Gewähr für die gemachten Angaben / Мы оставляем за собой право на внесение изменений без предварительного уведомления. Мы снимаем с себя любую ответственность в отношении предоставленной информации / حقوق التغيير محفوظة دون إشعار مسبق. بدون أدنى مسؤولية عن المعلومات المقدمة

			L (m)	A (m)	H (m)	P/W (kg)
Torre inferior / Lower tower Tour inférieure / Unterer Turm Нижняя башня / البرج السفلي	TLI20-5,6		5,886	2,306	2,357	4235
	TSI20-5,6		5,966	2,328	2,390	5390
	TSRI20-5,6		5,990	2,257	2,257	6562
	TRID24-5,6		5,990	3,202	3,202	8400
Torre / Tower Tour / Turm / Башня / برج	TL20		4,175	2,201	2,281	2095
	TL20-5,6		5,886	2,306	2,357	2910
	TS20-5,6A		5,978	2,381	2,331	3530
	TS20-5,6		5,966	2,328	2,390	3550
	TSR20-5,6A		5,926	2,388	2,325	4170
	TSR20-5,6		5,990	2,257	2,257	4210
	TR24-5,6		5,990	2,760	2,835	4760
TRD24-5,6	5,977	2,740	2,285	5280		
Torre asiento pista + punta de torre + orientación Slewing table + tower head + slewing mechanism Tour pivot + porte-flèche + mécanisme d'orientation Turmsitz + Turmspitze + Ausrichtung Сиденье площадки + верхней секции башни + поворотный механизм برج وحدة الدوارن + رأس البرج + آلية الدوران			5,319	2,51	2,52	8050
Punta de torre / Tower head / Porte-flèche Turmspitze / верхняя секция башни / رأس البرج			3,662	1,97	1,99	2600
Conjunto asiento pista, punta de torre, orientación Slewing table assembl +, tower head + slewing Groupe pivot + porte-flèche + mécanisme d'orientation Gruppe Turmsitz + Turmspitze + Ausrichtung Сиденье площадки + верхняя секция башни + поворотный механизм مجموعة وحدة الدوارن + رأس البرج + آلية الدوران			8,120	2,51	2,52	10650
Tramo de pluma Jib section Tronçon de flèche Auslegerabschnitt Секция стрелы أجزاء الذراع	PT19-11		10,180	1,740	2,180	2645
	PT19-12+Tr		10,220	1,600	2,240	3015
	PT19-13		5,280	1,600	2,195	1375
	PT19-14		10,200	1,600	2,000	2392
	PT19-15		10,200	1,600	2,000	1614
	PT19-16		10,190	1,600	2,000	1340
	PT19-17		5,160	1,600	2,000	577
PP19-18	0,685	1,740	0,665	176		
Tirante sostén pluma / Jib support tie / Tirant de fleche Haltestange Ausleger / Растяжка поддержки مشد دعامة الذراع			6,540	1,785	0,335	2270
Contrapluma II con mecanismos (sin cable) y plumín auxiliar Counterjib II with mechanism (without rope), and auxiliary jib Contre-flèche avec mécanisme (sans cale) et fléchette auxiliaire Gegenausleger II (ohne Seil) + Ausleger Противовесная консоль II с механизмами (без троса) и вспомогательной дополнительной стрелой الذراع المعاكس II مع آليات (بدون كابل) وريشة مساعدة			12,000	2,100	2,355	7535
Contrapluma I / Counterjib I / Contre-flèche I / Gegenausleger I / Противовесная консоль I / / الذراع المعاكس I			2,532	1,906	0,585	955
Carro / Trolley Chariot / Laufkatze Грузовая тележка / عرب	SR / DR		2,200	2,385	1,816	892
Polipasto / Hook assembly Palan / Flaschenzug Полиспаст / بكرة	SR / DR		1,376	0,400	1,651	510

LISTA DE EMBARQUE / PACKING LIST

LISTE DE COLISAGE / KOLLI LISTE / СПИСОК ПОСТАВКИ / قائمة التحميل

J360

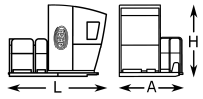
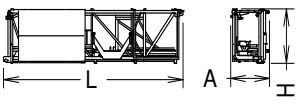
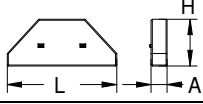
		L (m)	A (m)	H (m)	P/W (kg)	
Plataforma y cabina / Platform and cabin Plateforme et cabine / Plattform + Führerstand Платформа и кабина / منصة وكابينة		3,520	2,060	2,400	1.085	
Transporte torre de montaje Jacking cage transport Transport de tour de Montag Transport Montageturm Транспортировка монтажной башни نقل برج التركيب	TM20PALF-5,6 	9,955	1,851	2,525	6615	
Contrapeso / Counterweight Contrepoids / Gegengewicht Противовес / اوزان معاكسة	Lastre / Ballast / Lest Ballast / Балласт / ثقل		3,800 3,800 3,800	0,580 0,275 0,180	1,500 1,500 1,500	6000 3000 2000

LASTRES INFERIORES / LOWER BALLASTS

LESTS INFÉRIEURS / UNTERER BALLAST / НИЖНИЙ БАЛЛАСТ / ثقل

J360

BRI 10-24	H (m)	70,3	75,9	81,5
	P (t)	48	72	96
BSRI 8-20-5,6	H (m)	63,5	69,1	74,7
	P (t)	72	96	120
BSI 8-20-5,6	H (m)	51,7	57,3	62,9
	P (t)	48	60	72
BLI 6-20-5,6	H (m)	25,3	36,5	51,3
	P (t)	72	84	108

H: Altura bajo gancho / Height under hook / Hauteur maximale sous crochet / Höhe unter dem Haken / Высота под крюком / الارتفاع أسفل الخطاف

Para alturas intermedias tomar el lastre correspondiente a la altura superior / For intermediate heights take the ballast corresponding to the higher height / Pour les hauteurs intermédiaires, opter pour le lest correspondant à la hauteur immédiatement supérieure / Für Zwischenhöhen den entsprechenden Ballast auf für die höhere Höhe wählen / Для промежуточных высот возьмите балласт, соответствующий большей высоте / للارتفاعات البينية يرجى استخدام الثقل العائد / لارتفاع الأعلى.

TREPADO / CLIMBING / TÉLESCOPAGE / KLETTERSYSTEM / ЛЕСТНИЦА / التسلق

J360

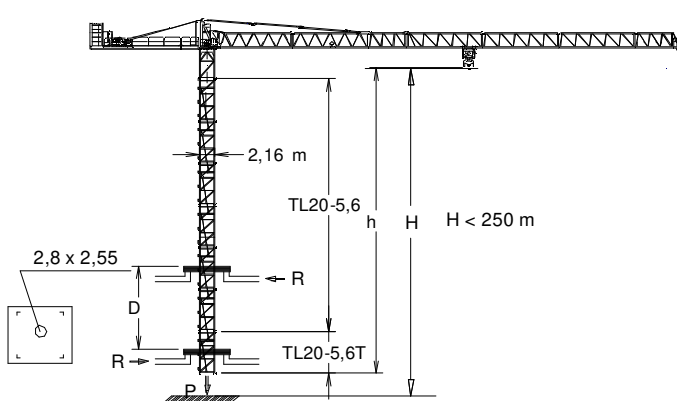

	h _{max} : TL20-5,6T + 6xTL20-5,6	
	▶	■
h (m)	40,9	
D (m)	14,6 - 19	
P (KN)	1180	1000
R _{max} (KN)	235	380
	TL20-5,6T: 136.32.700	

 Trepado interno / Internal climbing / TéléscoPAGE / Inneres klettersystem / Внутренняя лестница / التسلق الداخلي

 FEM 1005 - C25



29/11/2024

Reservado el derecho a modificaciones sin previo aviso. Declinamos toda responsabilidad derivada de la información proporcionada / Subject to modification, without prior notice. This information is supplied without liability / L'entreprise se réserve le droit de procéder à des modifications sans préavis. Nous déclinons toute responsabilité quant aux informations fournies / Das Recht auf Änderungen ohne vorherige Ankündigung bleibt vorbehalten. Wir übernehmen keine Gewähr für die gemachten Angaben / Мы оставляем за собой право на внесение изменений без предварительного уведомления. Мы снимаем с себя любую ответственность в отношении предоставленной информации / حقوق التغيير محفوظة دون إشعار مسبق. نحن أئدى مسؤولية عن المعلومات المقدمة /

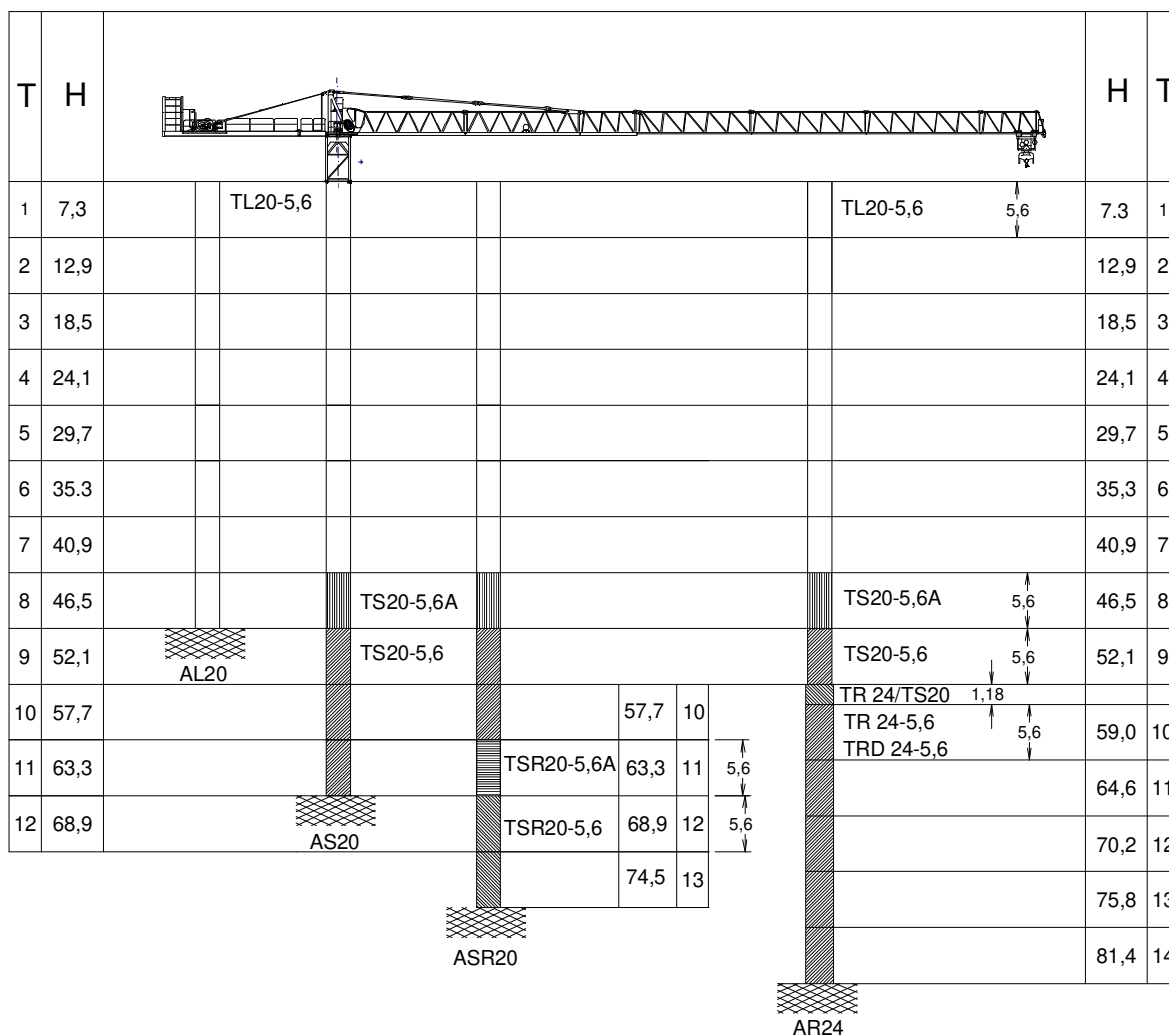

T : Torre / Tower / Tour / Turm / Башни / أبراج
H : Altura / Height / Hauteur / Höhe / Высота / ارتفاع

TL20.....	153.31.000	TSR20-5,6A.....	206.31.300	TRD24-5,6.....	163.31.300	ASD 20/24.....	160.21.080
TL20-5,6.....	204.31.400	TSR20-5,6.....	206.31.000	AL 20.....	153.21.800	ASR 20.....	160.21.200
TS20-5,6A.....	204.31.500	TR24/TS20.....	156.36.400	ALD 20.....	160.21.250	ASRD 20/24.....	156.21.000
TS20-5,6.....	204.31.200	TR24-5,6.....	156.30.700	AS 20.....	160.21.010	AR 24.....	156.21.200

Other configurations of tower / Other tower configuration / Autres configurations / Andere turmkonfigurationen / Прочие конфигурации / مكونات أخرى

TRANSPORTE / TRANSPORT / TRANSPORT / TRANSPORT / ТРАНСПОРТИРОВКА / نقل

J360



$$H = 8 \times TL20-5,6 + AL20 +$$

9 x



10 x



Viento fuera de servicio / Out of service wind / Vitesse du vent hors service / Wind außer betrieb / Ветровая нагрузка в покое / الريح خارج الخدمة

Consultar / Consult / Nous consulter / Anfragen / Консультируйтесь / الرجوع إلى

En servicio / In service / En service / In betrieb / В работе / في الخدمة

Fuera de servicio / Out of service / Hors service / Außer betrieb / В покое / خارج الخدمة

Opcional / Optional / En option / Optional / Опция / اختياري



Ctra./ Rd. Madrid – Irún - Km. 415 - 20213 IDIAZABAL (Gipuzkoa) - ESPAÑA / SPAIN
 P.O. Box, 23 - 20.200 - BEASAIN - E-mail: jaso@jaso.com
 Tel. +34 943 - 18 70 00 • Fax. +34 943 - 18 70 20
www.jaso.com

29/11/2024

FEM 1005 - C25

DELEGACIÓN / DEALER

Reservado el derecho a modificaciones sin previo aviso. Declinamos toda responsabilidad derivada de la información proporcionada / Subject to modification, without prior notice. This information is supplied without liability / L'entreprise se réserve le droit de procéder à des modifications sans préavis. Nous déclinons toute responsabilité quant aux informations fournies / Das Recht auf Änderungen ohne vorherige Ankündigung bleibt vorbehalten. Wir übernehmen keine Gewähr für die gemachten Angaben / Мы оставляем за собой право на внесение изменений без предварительного уведомления. Мы снимаем с себя любую ответственность в отношении предоставленной информации / حقوق التغيير محفوظة دون إشعار مسبق. دون أدنى مسؤولية عن المعلومات المقدمة