

$$HDR = H_{SR} - 0,5$$

H= **Altura máxima bajo gancho sin arriostrar (m) / Maximum height under hook without fastening (m) / Hauteur maximale sous crochet sans ancrage (m).**
Max. Hakenhöhe ohne Verstreben (m) / Максимальная высота под крюком без крепления (m) / (m) أقصى ارتفاع تحت الخطاف بدون ربط

* **Punta de pluma / Jib end / Pointe de flèche / Auslegerspitze / Конец стрелы / مقدمة الذراع**

P14-21N	158.40.000	P14-26N	158.45.500	T 6-90	133.31.000
P14-22N	158.41.000	Punta de pluma/Jib end*	158.46.000	TL 6-90	158.31.000
P14-23N	158.42.000	T 3-90	133.32.000	T 6-150	161.31.000
P14-24N	158.43.000	TL 3-90	158.32.000	T 6-150A	161.31.300
P14-25N	158.44.000				

CUSTOMIZE YOUR CRANE

OPTIMUS
line



(H_{SR}) ESTACIONARIA 1 / STATIONARY 1 / STATIONAIRE 1 / STATIONÄR 1 / СТАЦИОНАРНОЕ СОСТОЯНИЕ / ثابتة

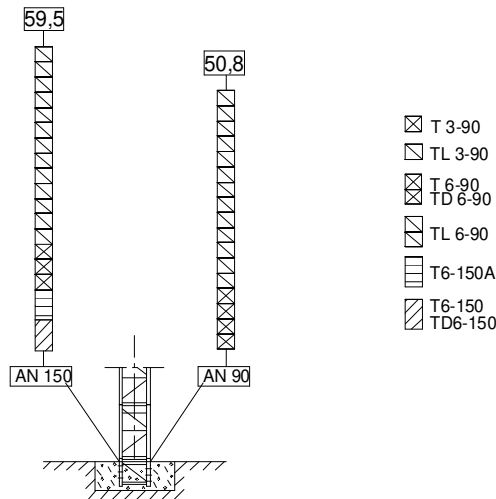

(H_{SR}) ESTACIONARIA 3 / STATIONARY 3 / STATIONAIRE 3 / STATIONÄR 3 / СТАЦИОНАРНОЕ СОСТОЯНИЕ / ثابتة

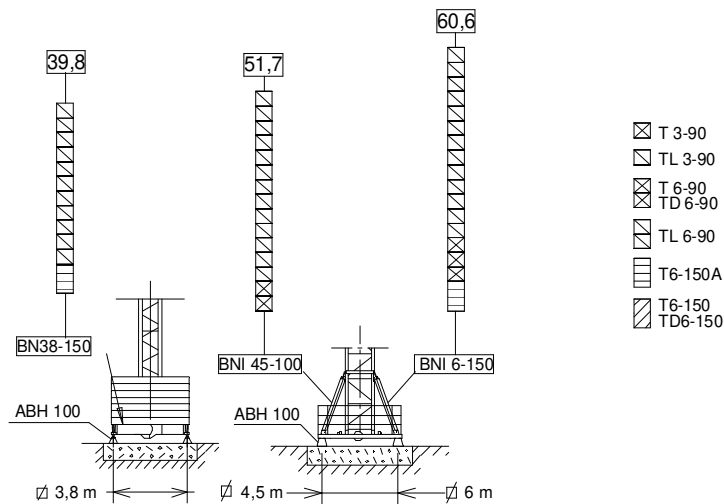

(H_{SR}) TRASLACIÓN / TRAVELLING / TRASLATION / FORTBEWEGUNG / ПЕРЕМЕЩЕНИЕ / متحركة

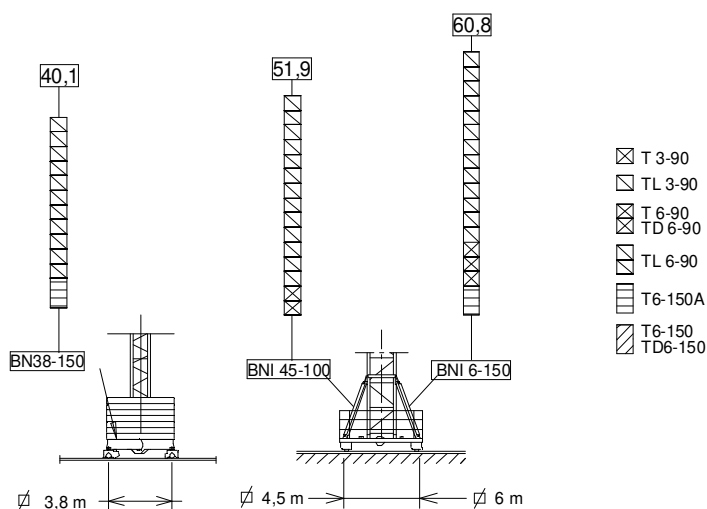

BN38-150.....	161.20.800
BNI 45-100	145.20.500

BNI 6-150	161.20.000
ABH 100	201.23.000

AN 90	133.21.000
AN 150	161.21.000

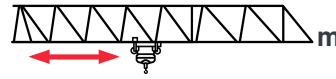

	3000 kg @ ... (m)	25	30	35	40	45	50	55
55	29,12	3000	2900	2430	2075	1800	1580	1400
50	32,35	3000	3000	2745	2350	2045	1800	—
45	34,41	3000	3000	2945	2525	2200	—	—
40	36,47	3000	3000	3000	2700	—	—	—
35	35,0	3000	3000	3000	—	—	—	—
30	30,0	3000	3000	—	—	—	—	—
25	25,0	3000	—	—	—	—	—	—

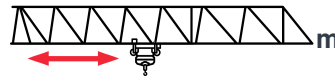
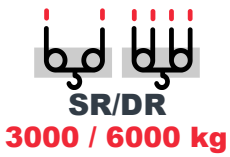

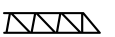
	3000 kg / 6000 kg @ ... (m)	15	20	25	30	35	40	45	50	55
55	27,5 / 15,0	3000 / 6000	3000 / 4350	3000 / 3360	2700	2230	1875	1600	1380	1200
50	30,56 / 16,67	3000 / 6000	3000 / 4900	3000 / 3800	3000 / 3065	2540	2150	1845	1600	—
45	32,5 / 17,75	3000 / 6000	3000 / 5250	3000 / 4080	3000 / 3300	2745	2325	2000	—	—
40	34,44 / 18,79	3000 / 6000	3000 / 5600	3000 / 4360	3000 / 3535	2945	2500	—	—	—
35	35,0 / 19,09	3000 / 6000	3000 / 5700	3000 / 4440	3000 / 3600	3000	—	—	—	—
30	30,0 / 18,64	3000 / 6000	3000 / 5550	3000 / 4320	3000 / 3500	—	—	—	—	—
25	25,0 / 19,32	3000 / 6000	3000 / 5775	3000 / 4500	—	—	—	—	—	—

Datos válidos para / Valid data for
Donnees valables pour / Gultige Daten für / Допустимые данные для / البيانات الصالحة لـ

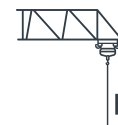

H ≤ 70 m



		EC2556 18,4 kW			* EC3380VF 24,2 kW		



$H \leq$ SR 240 m
DR 120 m



707 m

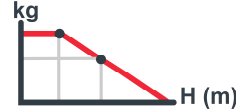

	OG1108VF 2 x 4 kW		TC465VF 3 kW		TG1125VF 2 x 4 kW		TH1210 9,2 kW

0...0,8
r/min
sl/min

0...15
15...32
32...65
m/min

0...25
m/min

1 m/min

3~ 400V 50Hz
480V 60Hz

KVA	
EC2556	33
EC3380VF	40

EC2556 KVA + 20%
TH1210 m/min + 20% 480V 60Hz

LASTRES INFERIORES / LOWER BALLASTS

LESTS INFÉRIEURS / UNTERER BALLAST / НИЖНИЙ БАЛЛАСТ / ثقيل

BN 38-150	H (m)	13,6		25,4		40,1	
	P (t)	36		48		72	
BNI 45-100	H (m)	19,4	31,2	40,1	46	51,9	
	P (t)	36	48	60	72	84	
BNI 6-150	H (m)	28	37	45,8	54,7	60,8	
	P (t)	36	48	60	72	96	

H: Altura bajo gancho / Height under hook / Hauteur maximale sous crochet / Höhe unter dem Haken / Высота под крюком / الارتفاع أسفل الخطاف

Para alturas intermedias tomar el lastre correspondiente a la altura superior / For intermediate heights take the ballast corresponding to the higher height / Pour les hauteurs intermédiaires, opter pour le lest correspondant à la hauteur immédiatement supérieure / Für Zwischenhöhen den entsprechenden Ballast auf für die höhere Höhe wählen / Для промежуточных высот возьмите балласт, соответствующий большей высоте / للارتفاعات البينية يرجى استخدام الثقل العائد للارتفاع الأعلى.

TREPADO / CLIMBING / TÉLESCOPAGE / KLETTERSYSTEM / ЛЕСТНИЦА / التسلق

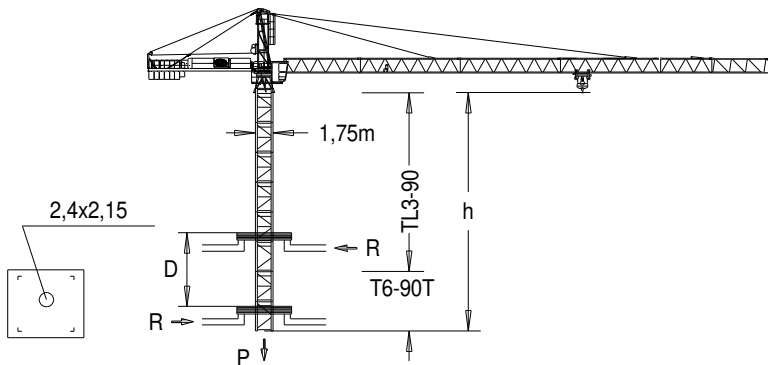

h_{max} :
T6-90T + 13xTL3-90

	▶	■
h (m)	44,9	
D (m)	10 - 20	
P (KN)	579	519
R_{max} (KN)	123	149

T6-90T = 139.32.700

Trepado interno / Internal climbing / Télescopage / Inneres klettersystem / Внутренняя лестница / التسلق الداخلي

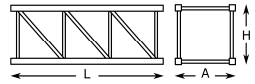
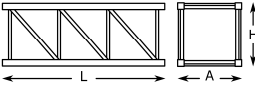
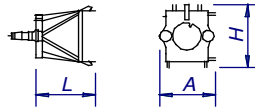
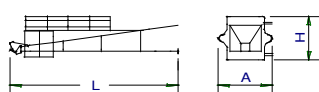
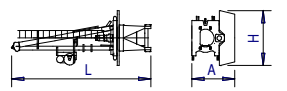
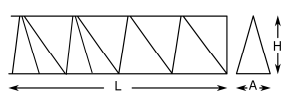
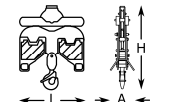
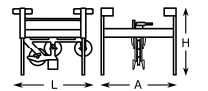
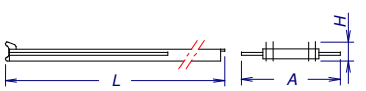
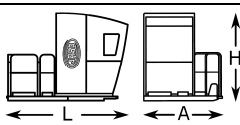
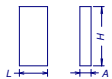
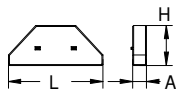
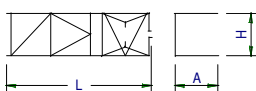

Reservado el derecho a modificaciones sin previo aviso. Declinamos toda responsabilidad derivada de la información proporcionada / Subject to modification, without prior notice. This information is supplied without liability / L'entreprise se réserve le droit de procéder à des modifications sans préavis. Nous déclinons toute responsabilité quant aux informations fournies / Das Recht auf Änderungen ohne vorherige Ankündigung bleibt vorbehalten. Wir übernehmen keine Gewähr für die gemachten Angaben / Мы оставляем за собой право на внесение изменений без предварительного уведомления. Мы снимаем с себя любую ответственность в отношении предоставленной информации / حقوق التغيير محفوظة دون إشعار مسبق. بدون أدنى مسؤولية عن المعلومات المقدمة /

			L (m)	A (m)	H (m)	P/W (kg)
Torre inferior / Lower tower Tour inférieure / Unterer Turm Нижняя башня / البرج السفلي	T16-90		6,146	2,085	2,085	2500
	T16-150		6,175	2,190	2,190	3535
Torre / Tower Tour / Turm / Башня / برج	T3-90		3,190	1,818	1,818	1200
	TL3-90		3,196	1,818	1,818	960
	T6-90		6,140	1,818	1,818	2250
	TL6-90		6,136	1,818	1,818	1785
	T6-150		6,175	1,870	1,870	2760
	T6-150A		6,175	1,870	1,870	2760
Torre asiento pista + punta de torre + orientación Slewing table + tower head + slewing mechanism Tour pivot + porte-flèche + mécanisme d'orientation Turmsitz + Turmspitze + Ausrichtung Сиденье площадки + верхней секции башни + поворотный механизм برج وحدة الدوارن + رأس البرج + آلية الدوران			3,390	2,060	2,150	3400
Punta de torre / Tower head / Porte-flèche Turmspitze / верхняя секция башни / رأس البرج			6,164	1,200	1,350	1210
Conjunto asiento pista, punta de torre, orientación Slewing table assembl +, tower head + slewing Groupe pivot + porte-flèche + mécanisme d'orientation Gruppe Turmsitz + Turmspitze + Ausrichtung Сиденье площадки + верхняя секция башни + поворотный механизм مجموعة وحدة الدوارن + رأس البرج + آلية الدوران			8,5	1,920	2,440	5660
Tramo de pluma Jib section Tronçon de flèche Auslegerabschnitt Секция стрелы أجزاء الذراع	P14-21N (1)		10,150	1,366	1,665	965
	P14-22N (2)		10,160	1,226	1,646	945
	P14-23N (3)		10,160	1,226	1,547	785
	P14-24N (4)		10,160	1,226	1,547	655
	P14-25N (5)		5,267	1,226	1,665	345
	P14-26N (6)		10,156	1,226	1,737	530
Polipasto / Hook assembly Palan / Flaschenzug Полиспаст / بكرة	SR		0,76	0,160	0,960	190
	DR		1	0,235	1,288	293
Carro / Trolley Chariot / Laufkatze Грузовая тележка / عرب	SR		1,100	1,330	0,730	195
	DR		1,410	1,471	1,204	295
Contrapluma con plataformas / Counterjib with platforms Contre-flèche avec plateformes Gegenausleger+Plattformen Противовесная консоль с платформами / الذراع المقابل مع المنصة			10,70	1,410	0,430	1575
Plataforma y cabina / Platform and cabin Plateforme et cabine / Plattform + Führerstand Платформа и кабина / منصة وكابينة			3,760	2,050	2,400	1280
Contrapeso / Counterweight Contrepoids / Gegengewicht Противовес / اوزان معاكسة	Grande / Big / Grand Groß / Большой / كبير		1,08	0,50	2,02	2360
	Pequeño / Small Petit / Klein / Малый / صغير		1,08	0,50	1,30	1500
Lastre / Ballast / Lest Ballast / Балласт / ثقل ثقيل			3,800	0,580	1,500	6000
Estructura torre de montaje / Jacking cage structure Structure de tour de montage / Konstruktion montageturm Структура монтажной башни هيكل برج التركيب نقل برج التركيب	TM 6-150		10,320	2,420	2,410	3500

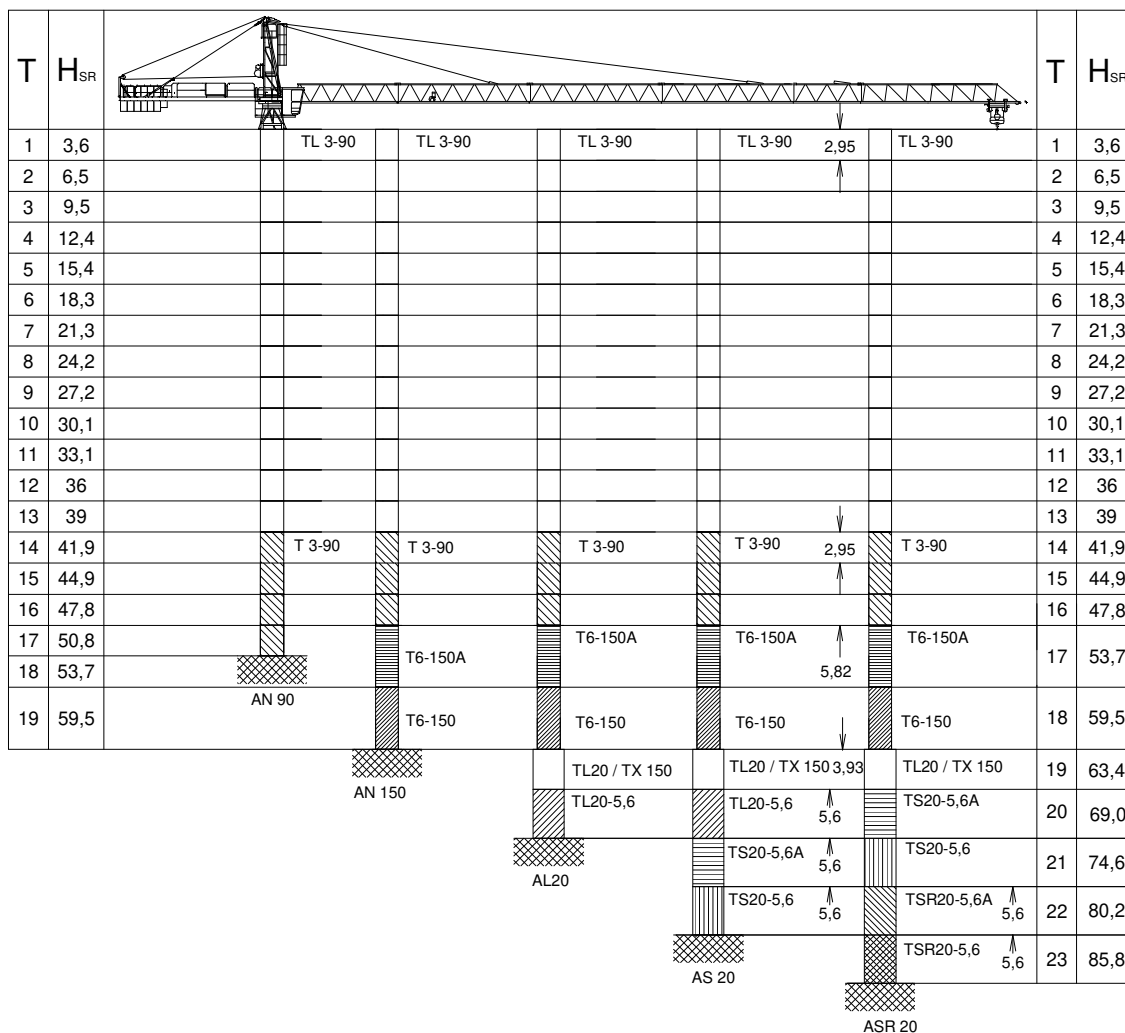

T : Torre / Tower / Tour / Turm / Башни / أبراج
 H : Altura / Height / Hauteur / Höhe / Высота / ارتفاع

T 3-90	133.32.000	TL20/TX-150	161.36.000	AN 90	133.21.000	ALD 20	160.21.250
TL 3-90	158.32.000	TL20-5,6	204.31.400	AND 90	133.21.800	AS 20	160.21.010
T 6-90	133.31.000	TS20-5,6A	204.31.500	AN150	161.21.000	ASD 20/24	160.21.080
TL 6-90	158.31.000	TS20-5,6	204.31.200	AND 150	161.21.050	ASR 20	160.21.200
T 6-150	161.31.000	TSR20-5,6A	206.31.300	AL 20	153.21.800	ASRD 20/24	156.21.000
T 6-150A	161.31.300	TSR20-5,6	206.31.000				

Otras configuraciones de torre / Other tower configuration / Autres configurations / Andere turmkonfigurationen / Прочие конфигурации / مكونات أخرى

TRANSPORTE / TRANSPORT / TRANSPORT / TRANSPORT / ТРАНСПОРТИРОВКА / نقل

$H = 1 \times T6-90 + 6 \times TL6-90 + 1 \times TL3-90 + BNI 45-100 +$

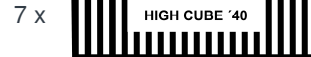

Viento fuera de servicio / Out of service wind / Vitesse du vent hors service / Wind außer betrieb / Ветровая нагрузка в покое / الريح خارج الخدمة

Consultar / Consult / Nous consulter / Anfragen / Консультируйтесь / الرجوع إلى

En servicio / In service / En service / In betrieb / В работе / في الخدمة

Fuera de servicio / Out of service / Hors service / Außer betrieb / В покое / خارج الخدمة

Opcional / Optional / En option / Optional / Опция / اختياري



Ctra./ Rd. Madrid – Irún - Km. 415 - 20213 IDIAZABAL (Gipuzkoa) - ESPAÑA / SPAIN
 P.O. Box, 23 - 20.200 - BEASAIN - E-mail: jaso@jaso.com
 Tel. +34 943 - 18 70 00 • Fax. +34 943 - 18 70 20
www.jaso.com

29/11/2024

FEM 1001

DELEGACIÓN / DEALER

Reservado el derecho a modificaciones sin previo aviso. Declinamos toda responsabilidad derivada de la información proporcionada / Subject to modification, without prior notice. This information is supplied without liability / L'entreprise se réserve le droit de procéder à des modifications sans préavis. Nous déclinons toute responsabilité quant aux informations fournies / Das Recht auf Änderungen ohne vorherige Ankündigung bleibt vorbehalten. Wir übernehmen keine Gewähr für die gemachten Angaben / Мы оставляем за собой право на внесение изменений без предварительного уведомления. Мы снимаем с себя любую ответственность в отношении предоставленной информации / حقوق التغيير محفوظة دون إشعار مسبق. دون أدنى مسؤولية عن المعلومات المقدمة