



UNE 58-101
FEM 1001

J700

GRUA TORRE / TOWER CRANE

GRUE A TOUR / TURMDREHKRAN / БАШЕННЫЙ КРАН / رافعة برجية

FEM 1001

UNE-EN-ISO 9001

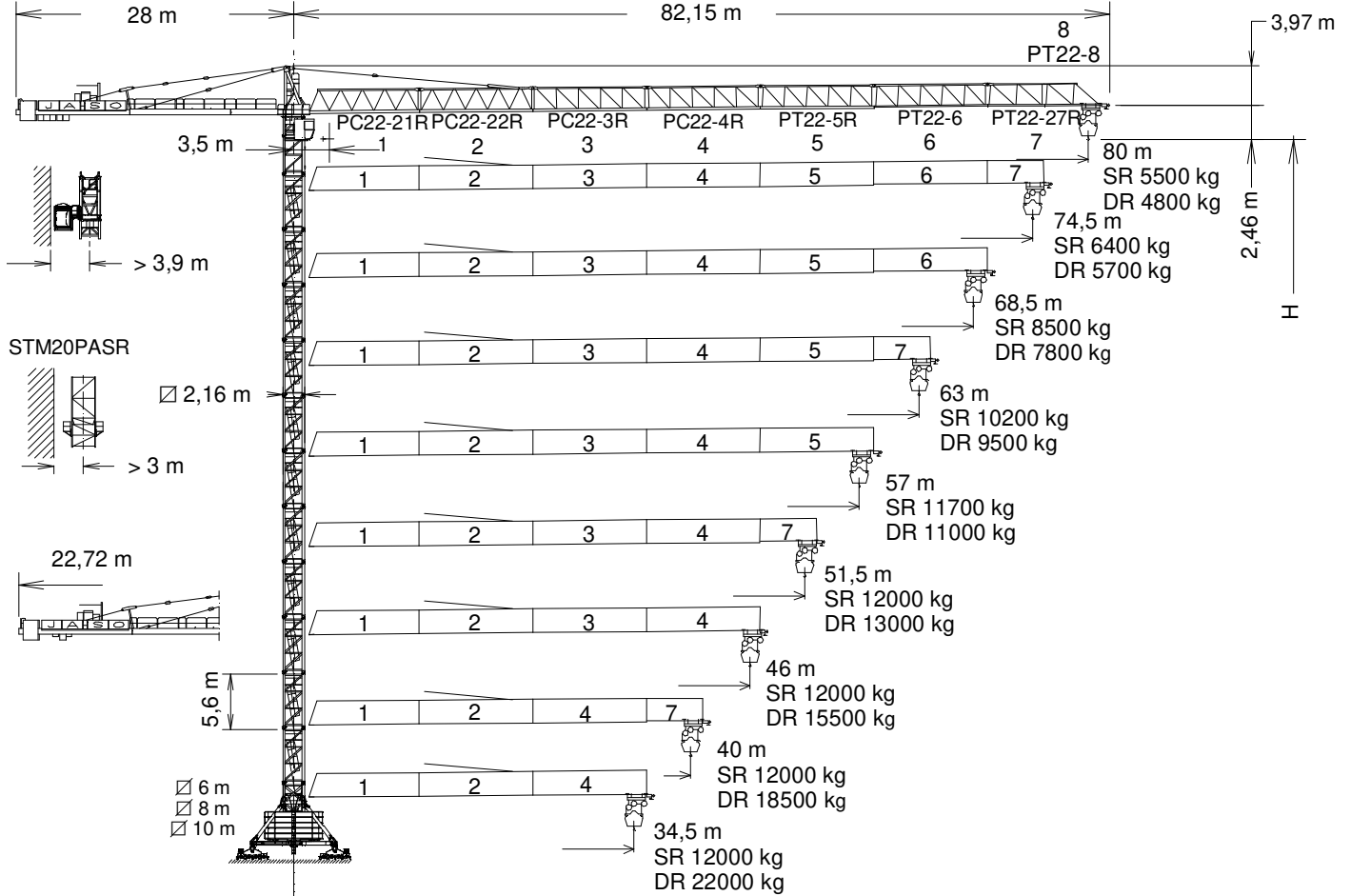

H= Altura máxima bajo gancho sin arriostrar (m). / Maximum height under hook without fastening (m). / Hauteur maximale sous crochet sans ancrage (m).
Max. Hakenhöhe ohne Verstreben (m). / Максимальная высота под крюком без крепления (m). / أقصى ارتفاع تحت الخطاف بدون ربط (m)

PC22-21R	156.40.700	PT22-5R	156.44.200	TSR20	206.31.200	TR24-5,6	206.32.000
PC22-22R	156.41.400	PT22-6	156.45.000	TSR20-5,6	206.31.000	TRD24-5,6	206.32.300
PC22-3R	156.42.200	PT22-27R	156.46.400	TR24/TSR20	204.36.000		
PC22-4R	156.43.500	PT22-8	156.47.000				

CUSTOMIZE YOUR CRANE

OPTIMUS
line JASD



OPTI Cubo



TC Diagnosis SYSTEM



CLIMBING Solution



SAFETY Pack



Customization



ECO Mode



COMFORT Cabin



HIGH POWER Motors



JL25 Tower Crane Elevator



BE SMART keep control



Reservado el derecho a modificaciones sin previo aviso. Declinamos toda responsabilidad derivada de la información proporcionada / Subject to modification, without prior notice. This information is supplied without liability / L'entreprise se réserve le droit de procéder à des modifications sans préavis. Nous déclinons toute responsabilité quant aux informations fournies / Das Recht auf Änderungen ohne vorherige Ankündigung bleibt vorbehalten. Wir übernehmen keine Gewähr für die gemachten Angaben / Мы оставляем за собой право на внесение изменений без предварительного уведомления. Мы снимаем с себя любую ответственность в отношении предоставленной информации / حقوق التغيير محفوظة دون إشعار مسبق. بدون أدنى مسؤولية عن المعلومات المقدمة

14/01/2025

(H) ESTACIONARIA 1 / STATIONARY 1 / STATIONAIRE 1 / STATIONÄR 1 / СТАЦИОНАРНОЕ СОСТОЯНИЕ / ثابتة

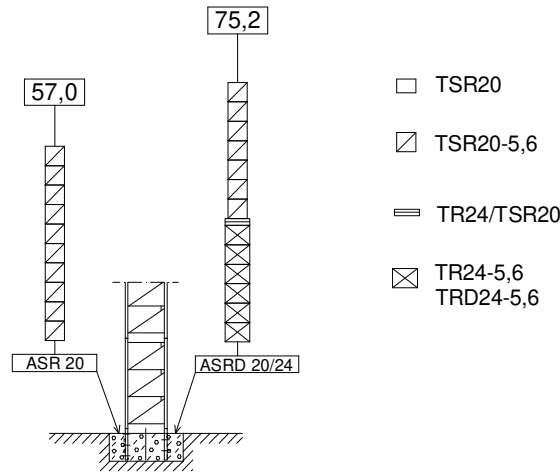

(H) ESTACIONARIA 3 / STATIONARY 3 / STATIONAIRE 3 / STATIONÄR 3 / СТАЦИОНАРНОЕ СОСТОЯНИЕ / ثابتة

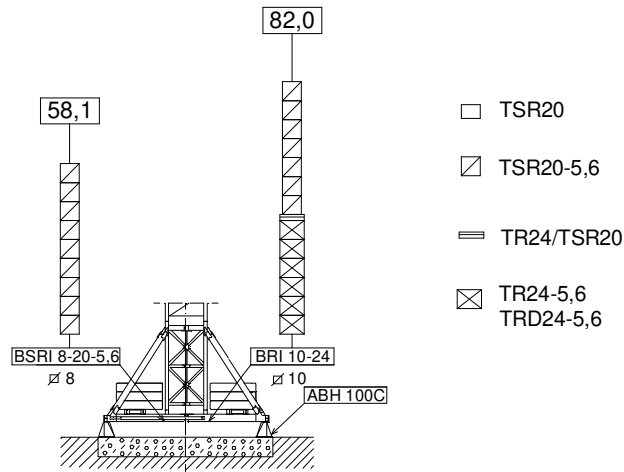

(H) TRASLACION / TRAVELLING / TRASLATION / FORTBEWEGUNG / ПЕРЕМЕЩЕНИЕ / متحركة

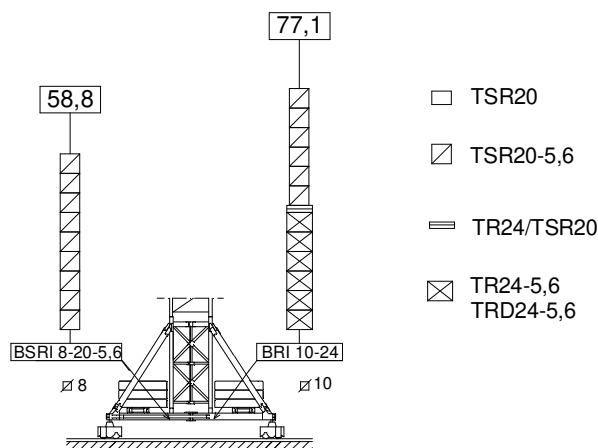

ASR20 160.21.200
ASRD 20/24 156.21.000

BSRI 8-20-5,6 204.20.000
BRI 10-24 156.20.500

ABH 100C 170.23.000

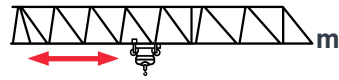

 12 t @ ... (m)	25,0	30,0	34,5	40,0	46,0	51,5	57,0	63,0	68,5	74,5	80,0	
80,0	43,4	12,00	12,00	12,00	12,00	11,20	9,76	8,61	7,58	6,79	6,07	5,50
74,5	45,1	12,00	12,00	12,00	12,00	11,73	10,24	9,04	7,97	7,15	6,4	—
68,5	51,6	12,00	12,00	12,00	12,00	12,00	12,00	10,66	9,43	8,5	—	—
63,0	55,0	12,00	12,00	12,00	12,00	12,00	12,00	11,54	10,20	—	—	—
57,0	55,8	12,00	12,00	12,00	12,00	12,00	12,00	11,70	—	—	—	—
51,5	51,5	12,00	12,00	12,00	12,00	12,00	12,00	—	—	—	—	—
46,0	46,0	12,00	12,00	12,00	12,00	12,00	—	—	—	—	—	—
40,0	40,0	12,00	12,00	12,00	12,00	—	—	—	—	—	—	—
34,5	34,5	12,00	12,00	12,00	—	—	—	—	—	—	—	—

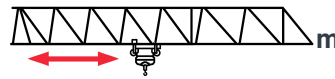

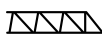
 24 t @ ... (m)	25,0	30,0	34,5	40,0	46,0	51,5	57,0	63,0	68,5	74,5	80,0	
80,0	23,0	21,82	17,69	15,00	12,53	10,52	9,08	7,92	6,89	6,10	5,37	4,80
74,5	23,9	22,80	18,51	15,71	13,15	11,05	9,56	8,35	7,28	6,46	5,70	—
68,5	27,3	24,00	21,58	18,38	15,45	13,05	11,34	9,97	8,74	7,80	—	—
63,0	29,1	24,00	23,18	19,77	16,65	14,10	12,28	10,81	9,50	—	—	—
57,0	29,5	24,00	23,54	20,09	16,92	14,33	12,49	11,00	—	—	—	—
51,5	30,5	24,00	24,00	20,85	17,58	14,90	13,00	—	—	—	—	—
46,0	31,5	24,00	24,00	21,64	18,26	15,50	—	—	—	—	—	—
40,0	31,8	24,00	24,00	21,92	18,50	—	—	—	—	—	—	—
34,5	31,9	24,00	24,00	22,00	—	—	—	—	—	—	—	—

Datos válidos para / Valid data for
Données valables pour / Gültige Daten für / Допустимые данные для / البيانات الصالحة لـ

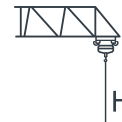

H ≤ 70 m





EC88115VF
65 kW

*** EC150185VF**
110 kW

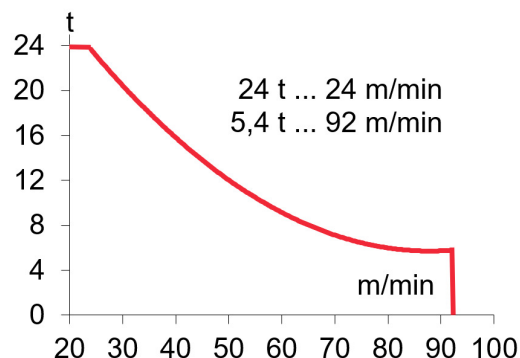
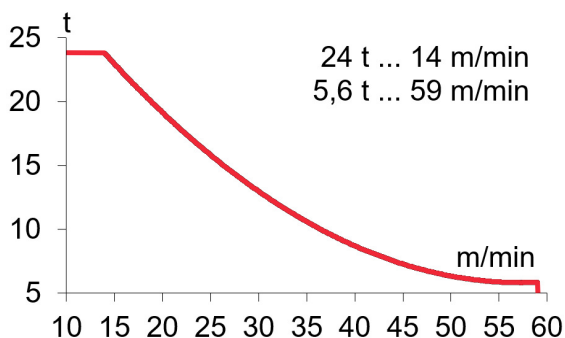
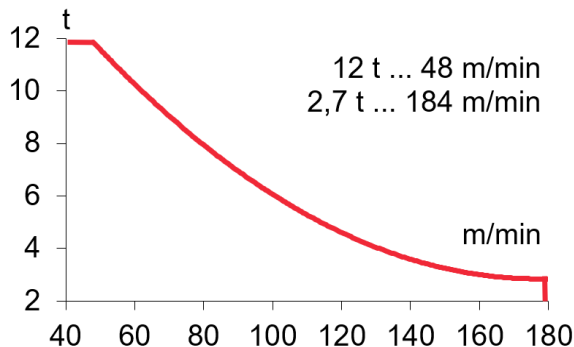
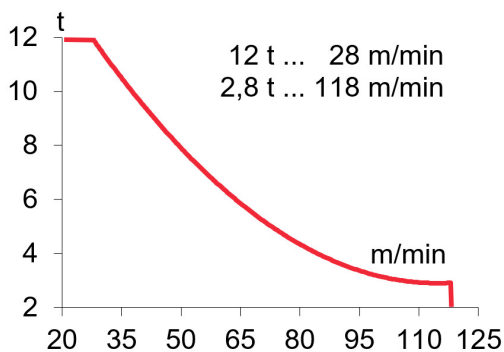

H ≤ SR 366 m
DR 183 m



H ≤ SR 436 m
DR 218 m

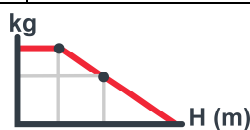

OG4006VF
4 x 7,5 kW



TC15105VF
11 kW

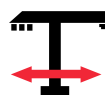

TG4025VF
4 x 7,5 kW

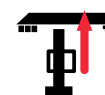

TH4010
29,4 kW

0...0,8
r/min
sl/min



12 t
0...105 m/min
24 t
0...52 m/min

0...25
m/min

0,6 m/min

⚡ 3~ 400V 50Hz
480V 60Hz

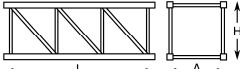
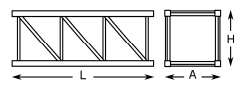
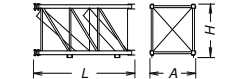
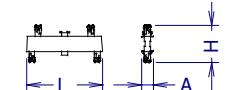
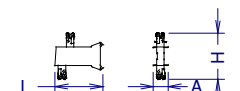
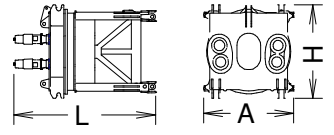
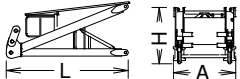
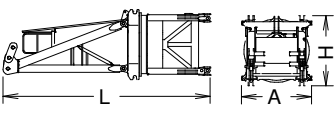
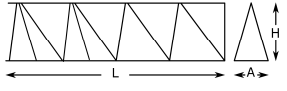
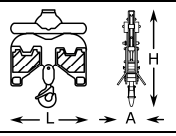
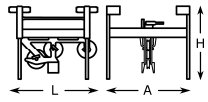
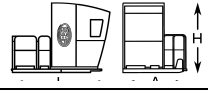
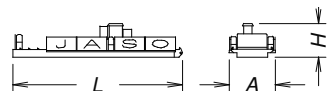
KVA			
EC88115VF	78	94	109
EC150185VF	100	126	153

			L (m)	A (m)	H (m)	P/W (kg)
Torre inferior / Lower tower Tour inférieure / Unterer Turm البرج السفلي	TSRI-20-5,6		5,990	2,257	2,257	6860
Torre / Tower Tour / Turm / Башня / برج	TSR20 TSR20-5,6 TR24-5,6		4,260 5,990 5,990	2,251 2,257 2,760	2,251 2,257 2,835	3110 4210 4760
Torre desmontada / Dismantled tower Tour démontée / Demontierter Turm Разобранная башня / برج مفكك	TRD24-5,6		5,990	1,170	2,545	5280
Larguero largo, reducción / Long rossbar, reduction / Traverse longue, reduction Langer Längsträger, Reduzierung / линия продольная балка / عارضة طويلة، مُصغر	TR24/TSR20		4,856	0,630	1,670	2850
Larguero corto reducción / Short crossbar, reduction / Traverse courte, réduction / urzer Längsträger, Reduzierung / Короткая продольная балка, уменьшение عارضة قصيرة، مُصغر	TR24/TSR20		2,370	0,564	1,670	1445
Torre asiento pista + base punta de torre + orientación Slewling table + tower head base + slewing mechanism Tour pivot + base du porte-flèche + mécanisme d'orientation Turmsitz + Turmspitzebasis + Ausrichtung Сиденье площадки основание верхней секции башни + оворотный механизм آلية الدوران وحدة الدوارن + قاعدة رأس البرج			4,706	2,480	2,550	12320
Punta de torre / Tower head / Porte-flèche Turmspitze / верхняя секция башни / رأس البرج			4,363	2,230	2,008	4305
Conjunto asiento pista, punta de torre y orientación Slewling table assembly, tower head and slewing mechanism / Groupe pivot + porte-flèche + mécanisme d'orientation / Gruppe Turmsitz + Turmspitze + Ausrichtung Сиденье площадки + верхняя секция башни + оворотный механизм / مجموعة وحدة الدوارن + رأس البرج + آلية الدوران			8,135	2,481	2,550	16625
Tramo de pluma Jib section Tronçon de flèche Auslegerabschnitt Секция стрелы أجزاء الذراع	PC22-21R (1) PC22-22R (2) PC22-3R (3) PC22-4R (4) + Tr PT22-5R (5) PT22-6 (6) PT22-27R (7) PT22-8 (8)		11,645 11,742 11,742 11,742 11,742 11,742 5,917 5,860	2,226 2,266 2,06 2,060 2,060 2,060 2,060 2,060	2,502 2,467 2,467 2,467 2,455 2,455 2,430 2,405	5300 5898 6135 5810 3045 2135 1185 905
Polipasto / Hook assembly Palan / Flaschenzug Полиспаст / بكرة	ST/DR		2,070	0,710	1,370	1135
Carro / Trolley Chariot / Laufkatze Грузовая тележка / عرب	ST/DR		3,260	2,330	2,200	1365
Plataforma y cabina / Platform and cabin Plateforme et cabine / Plattform + Führerstand Платформа и кабина / منصة وكابينة			3,860	2,240	2,500	1160
Contrapluma con plataformas / Counterjib with platforms Contre-flèche avec plateformes / Gegenausleger+Plattformen Противовесная консоль с платформами / المنصة مع المقابل			11,510	3,403	2,325	9565
Transporte torre de montaje / Jacking cage transport Transport de tour de montage / Transport Montageturm Транспортировка монтажной башни / نقل برج التركيب	TM20PASR-5,6		10,820	2,285	2,395	12140

		L (m)	A (m)	H (m)	P/W(kg)
Prolongación larga de contrapluma con plataformas Large counterjib extension with platforms Prolongement long de contre-flèche avec plateformes Lange Verlängerung des Gegenauslegers mit Plattform Длинное удлинение противовесной консоли с платформами / امتداد طويل للذراع المعاكس مع الممرات		10,350	2,020	0,880	4275
Prolongación contrapluma con plataforma / Counterjib extension with platform Prolongement contre-flèche avec plateforme / Verlängerung Gegenausleger mit Plattform Удлинение противовесной консоли с платформой / امتداد الذراع المعاكس مع الممرات		5,480	2,020	0,945	2560
Soporte y elevación (sin cable) / Support and hoisting (without rope) Support et levage (sans câble) / Опора и подъем (без троса) / Abstützung und Hebewerk (ohne Seil) دعم ورفع (بدون كابل)		2,500	2,100	1,250	3550

LASTRES INFERIORES / LOWER BALLASTS

LESTS INFÉRIEURS / UNTERER BALLAST / НИЖНИЙ БАЛЛАСТ / ثقل

BRI 10-24	H (m)	60,3	82
	P (t)	48	84
BSRI 8-20-5,6	H (m)	36,4	58,8
	P (t)	72	120

H: Altura bajo gancho / Height under hook / Hauteur maximale sous crochet / Höhe unter dem Haken / Высота под крюком / الارتفاع أسفل الخطاف

Para alturas intermedias tomar el lastre correspondiente a la altura superior / For intermediate heights take the ballast corresponding to the higher height / Pour les hauteurs intermédiaires, opter pour le lest correspondant à la hauteur immédiatement supérieure / Für Zwischenhöhen den entsprechenden Ballast auf für die höhere Höhe wählen / Для промежуточных высот возьмите балласт, соответствующий большей высоте / للارتفاعات البينية يرجى استخدام الثقل العائد للا ارتفاع الأعلى.

TREPADO / CLIMBING / TÉLESCOPAGE / KLETTERSYSTEM / ЛЕСТНИЦА / التسلق

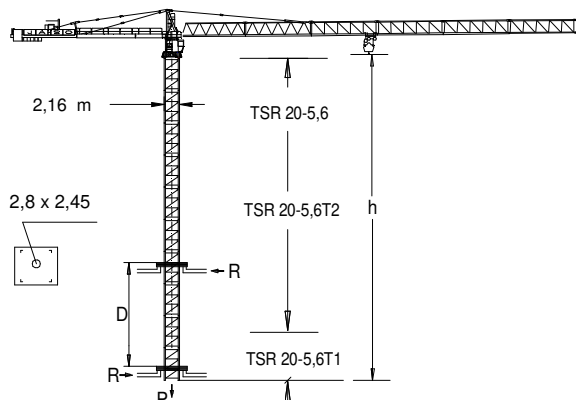

h _{max} :	
TSR20-5,6T1 + 5 x TSR20-5,6 + TSR20-5,6T2	
h (m)	40,2
D (m)	14,3 - 18
P (KN)	1663 1423
R _{max} (KN)	445 582
TSR20-5,6T1: 206.31.400	
TSR20-5,6T2: 206.31.500	

Trepado interno / Internal climbing / Télescopage / Inneres klettersystem / Внутренняя лестница / التسلق الداخلي

Viento fuera de servicio / Out of service wind / Vitesse du vent hors service / Wind außer betrieb / Ветровая нагрузка в покое / الريح خارج الخدمة

Consultar / Consult / Nous consulter / Anfragen / Консультируйтесь / الرجوع إلى

En servicio / In service / En service / In betrieb / В работе / في الخدمة

Fuera de servicio / Out of service / Hors service / Außer betrieb / В покое / خارج الخدمة

Opcional / Optional / En option / Optional / Опция / اختياري



Ctra./ Rd. Madrid – Irún - Km. 415 - 20213 IDIAZABAL (Gipuzkoa) - ESPAÑA / SPAIN
 P.O. Box, 23 - 20.200 - BEASAIN - E-mail: jaso@jaso.com
 Tel. +34 943 - 18 70 00 • Fax. +34 943 - 18 70 20
www.jaso.com

14/01/2025



FEM 1001

DELEGACIÓN / DEALER

Reservado el derecho a modificaciones sin previo aviso. Declinamos toda responsabilidad derivada de la información proporcionada / Subject to modification, without prior notice. This information is supplied without liability / L'entreprise se réserve le droit de procéder à des modifications sans préavis. Nous déclinons toute responsabilité quant aux informations fournies / Das Recht auf Änderungen ohne vorherige Ankündigung bleibt vorbehalten. Wir übernehmen keine Gewähr für die gemachten Angaben / Мы оставляем за собой право на внесение изменений без предварительного уведомления. Мы снимаем с себя любую ответственность в отношении предоставленной информации / حقوق التغيير محفوظة دون إشعار مسبق. دون أدنى مسؤولية عن المعلومات المقدمة