

*OPTIONAL EXTRA LIFT

H= Altura máxima bajo gancho sin arriostrar (m). / Maximum height under hook without fastening (m).

CUSTOMIZE YOUR CRANE

OPTIMUS
line JASD

EXTRA Lift	OPTI Cube	TC Diagnose SYSTEM	CLIMBING Solutions	SAFETY Pack	Personalization	ECO Mode	COMFORT Cabin	HIGH POWER Motors	JL25 Tower Crane Elevator	SMARTLINK BE SMART keep control
------------	-----------	--------------------	--------------------	-------------	-----------------	----------	---------------	-------------------	---------------------------	---------------------------------

(H) ESTACIONARIA 1 / STATIONARY 1

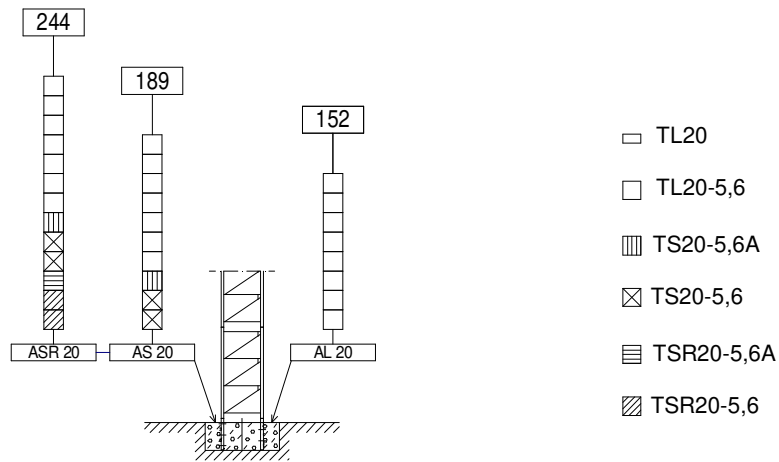

(H) ESTACIONARIA 3 / STATIONARY 3

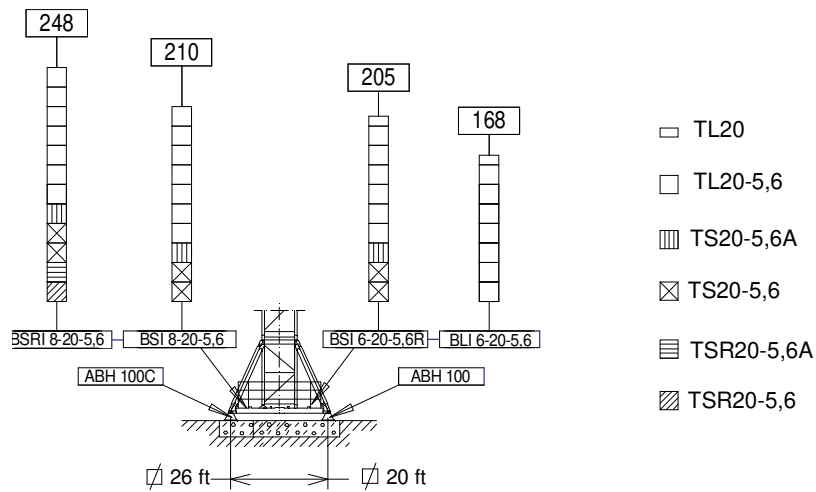

(H) TRASLACION / TRAVELLING

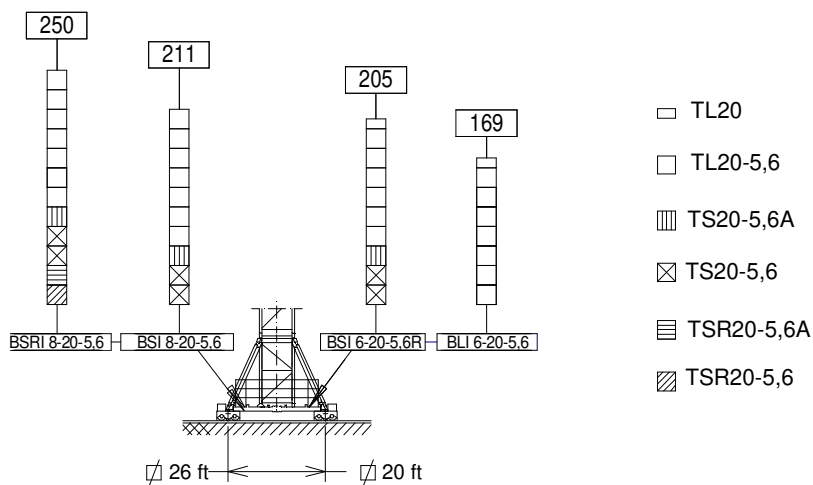

SR - 26500 lb

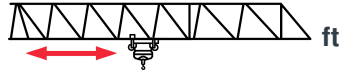

EXTRA Lift

	26500 lb @ ... (ft)	49	66	82	98	115	131	148	164	180	197	213	230	246	
246	91	26500	26500	26500	24300	20500	17600	15400	13700	12200	11000	10000	9100	8400	
	95	26500	26500	26500	25500	21600	18700	16400	14600	13100	11900	10900	10000	9200	+
230	94	26500	26500	26500	25100	21200	18300	16000	14200	12700	11400	10400	9500	—	
	98	26500	26500	26500	26300	22300	19300	17000	15100	13600	12400	11300	10400	—	+
213	97	26500	26500	26500	26000	22000	18900	16600	14700	13200	11900	10800	—	—	
	101	26500	26500	26500	26500	23100	20100	17700	15800	14200	12900	11800	—	—	+
197	101	26500	26500	26500	26500	23100	20000	17500	15500	14600	12600	—	—	—	
	106	26500	26500	26500	26500	24300	21200	18700	16700	15100	13700	—	—	—	+
180	107	26500	26500	26500	26500	24500	21100	18500	16500	14800	—	—	—	—	
	112	26500	26500	26500	26500	25700	22300	19700	17600	15900	—	—	—	—	+
164	112	26500	26500	26500	26500	25800	22300	19600	17400	—	—	—	—	—	
	117	26500	26500	26500	26500	26500	23500	20700	18500	—	—	—	—	—	+
148	117	26500	26500	26500	26500	26500	23300	20500	—	—	—	—	—	—	
	122	26500	26500	26500	26500	26500	24500	21500	—	—	—	—	—	—	+
131	120	26500	26500	26500	26500	26500	24000	—	—	—	—	—	—	—	
	125	26500	26500	26500	26500	26500	25100	—	—	—	—	—	—	—	+
115	115	26500	26500	26500	26500	26500	—	—	—	—	—	—	—	—	
	115	26500	26500	26500	26500	26500	—	—	—	—	—	—	—	—	+
98	98	26500	26500	26500	26500	—	—	—	—	—	—	—	—	—	
	98	26500	26500	26500	26500	—	—	—	—	—	—	—	—	—	+

SR / DR (t) - 26500 / 52900 lb

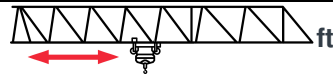

EXTRA Lift

	26500 / 52900 lb @ ... (ft)	49	66	82	98	115	131	148	164	180	197	213	230	246	
246	86/46	26500/49100	26500/35800	26500/27800	22500	18700	15900	13700	11900	10500	9300	8200	7400	6600	
	88/47	26500/50200	26500/36800	26500/28800	23400	19600	16700	14400	12700	11200	10000	8900	8000	7300	+
230	88/47	26500/50700	26500/37000	26500/28800	23300	19400	16500	14200	12400	10900	9700	8600	7700	—	
	91/48	26500/51900	26500/38100	26500/29800	24300	20300	17350	15000	13200	11700	10400	9400	8500	—	+
213	91/49	26500/52500	26500/38400	26500/29900	24300	20200	17200	14800	12900	11400	10100	9000	—	—	
	94/50	26500/52900	26500/39500	26500/30900	25200	21100	18100	15700	13800	12300	11000	9900	—	—	+
197	96/51	26500/52900	26500/40400	26500/31500	25600	21400	18200	15700	13800	12100	10800	—	—	—	
	99/52	26500/52900	26500/41500	26500/32600	26700	22400	19200	16800	14800	13100	11800	—	—	—	+
180	97/54	26500/52900	26500/42800	26500/33400	26500/27200	22700	19400	16800	14700	13000	—	—	—	—	
	105/55	26500/52900	26500/43900	26500/34600	26500/28300	23900	20500	17924	15800	14100	—	—	—	—	+
164	106/57	26500/52900	26500/45100	26500/35300	26500/28700	24100	20600	17800	15700	—	—	—	—	—	
	110/58	26500/52900	26500/46300	26500/36500	26500/29900	25300	21800	19026	16850	—	—	—	—	—	+
148	110/59	26500/52900	26500/47200	26500/36900	26500/30100	25200	21600	18700	—	—	—	—	—	—	
	115/60	26500/52900	26500/48300	26500/38100	26500/31300	26400	22800	19950	—	—	—	—	—	—	+
131	113/61	26500/52900	26500/48500	26500/38000	26500/31000	26000	22300	—	—	—	—	—	—	—	
	118/62	26500/52900	26500/49700	26500/39200	26500/32200	27200	23500	—	—	—	—	—	—	—	+
115	115/62	26500/52900	26500/49700	26500/38900	26500/31800	26500/26700	—	—	—	—	—	—	—	—	
	115/63	26500/52900	26500/50800	26500/40100	26500/33000	26500/27800	—	—	—	—	—	—	—	—	+
98	98/63	26500/52900	26500/50900	26500/39900	26500/32600	—	—	—	—	—	—	—	—	—	
	98/65	26500/52900	26500/52100	26500/41100	26500/33700	—	—	—	—	—	—	—	—	—	+

Datos válidos para / Valid data for

H ≤ 230 ft



FEM 1005 - C25



*OPCIONAL / OPTIONAL

***EC6080VF**
45 kW

EC88115VF
65 kW

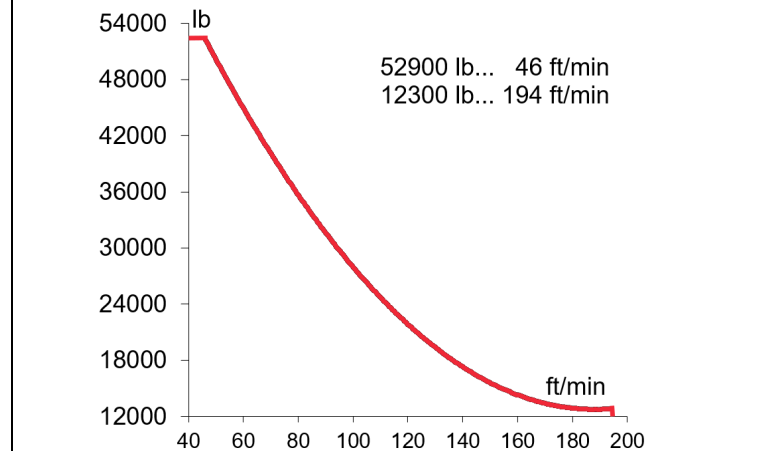
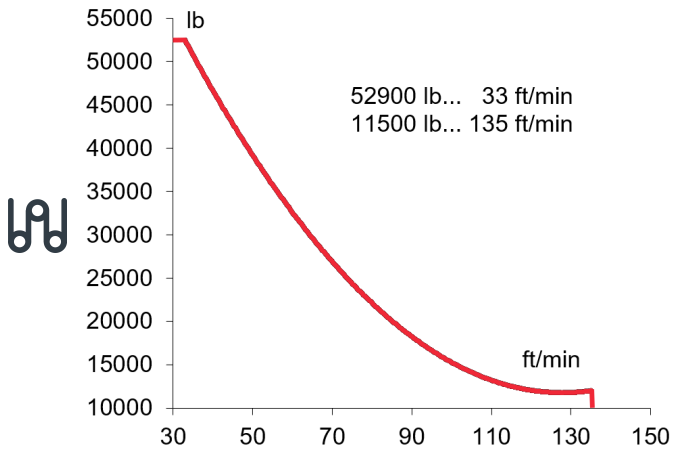
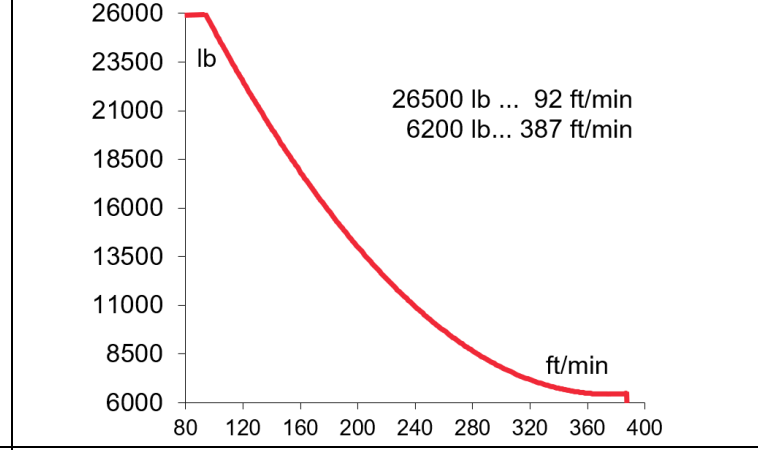
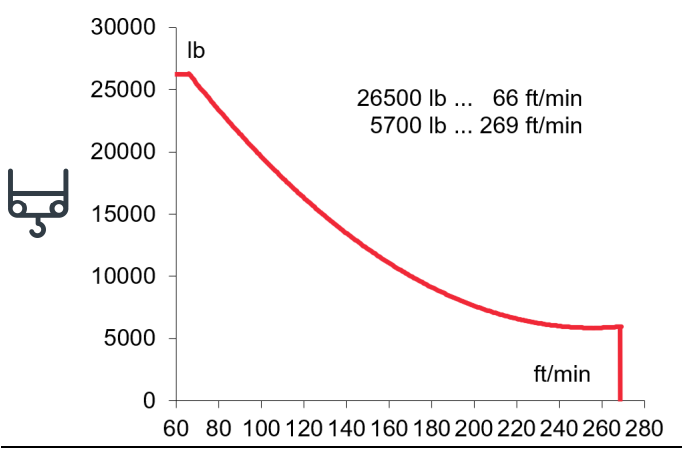

$H \leq \begin{matrix} \text{SR} & 1017 \text{ ft} \\ \text{DR} & 509 \text{ ft} \end{matrix}$

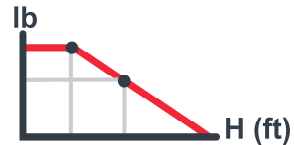

 <p>OG2208VF 3 x 5,5 kW</p>	 <p>TC1595VF 11 kW</p>	 <p>TG4025VF 4 x 7,5 kW</p>	 <p>TH2006 15 kW</p>
<p>0...0,8 r/min sl/min</p>	<p>26500 lb 0...308 ft/min 52900 lb 0...154 m/min</p>	<p>0...82 ft/min</p>	<p>2 ft/min</p>

EC6080VF: AMPERAGE = 121 A
EC88115VF: AMPERAGE = 152 A

 **480V 60Hz**

H: Altura bajo gancho / Height under hook

Para alturas intermedias tomar el lastre correspondiente a la altura superior / For intermediate heights take the ballast corresponding to the higher height



FEM 1005 - C25



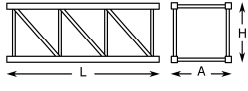
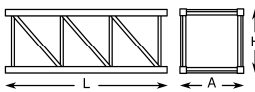
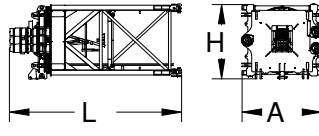
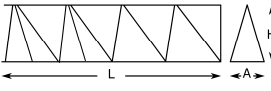
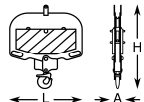
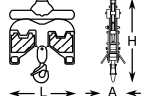
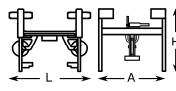
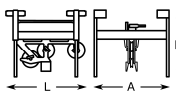
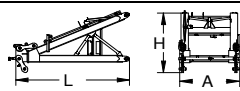
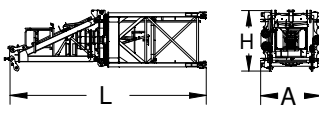
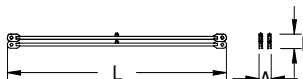

Reservado el derecho a modificaciones sin previo aviso. Declinamos toda responsabilidad derivada de la información proporcionada / Subject to modification, without prior notice. This information is supplied without liability

			L (ft)	A (ft)	H (ft)	P/W (lb)
Torre inferior / Lower tower	TLI20-5,6		19.3	7.6	7.7	9340
	TSI20-5,6		19.6	7.6	7.8	11880
	TSRI20-5,6		19.7	7.4	7.4	14470
	TRID24-5,6		19.7	10.5	10.5	18520
Torre / Tower	TL20		13.7	7.2	7.5	4620
	TL20-5,6		19.3	7.6	7.7	6415
	TS20-5,6A		19.6	7.8	7.6	7780
	TS20-5,6		19.6	7.6	7.8	7830
	TSR20-5,6A		19.4	7.8	7.6	9200
	TSR20-5,6		19.7	7.4	7.4	9290
	TR24-5,6		19.7	9.1	9.3	10490
	TRD24-5,6		19.6	9.0	7.5	11640
Torre asiento pista + punta de torre + orientación Slewing table + tower head + slewing mechanism		17.5	8.2	8.3	16865	
Tramo de pluma Jib section	PT19-31		33.3	5.2	7.2	6810
	PT19-32+Tr		33.5	5.2	7.4	8060
	PT19-33		17.4	5.2	7.2	3680
	PT19-34		33.7	5.2	7.2	6300
	PT19-35		33.6	5.2	6.7	4920
	PT19-36		33.6	5.2	6.7	3570
	PT19-37		33.5	5.2	6.7	2480
	PT19-28		33.4	5.7	6.7	2130
	PP19-39		3.4	5.7	2.5	455
Polipasto / Hook assembly	SR - 26500 lb		4.4	1.0	4.3	880
	SR / DR - 52900 lb		4.9	1.3	5.5	1550
Carro / Trolley	SR - 26500 lb		7.6	7.9	5.3	1370
	SR / DR - 52900 lb		8.7	7.7	7.0	2460
Punta de torre / Tower head		12.0	6.5	6.5	5030	
Conjunto asiento pista, punta de torre, orientación Slewing table assembl +, tower head + slewing		26.6	8.2	8.3	21890	
Tirante sostén pluma / Jib support tie		21.5	5.9	1.1	7000	

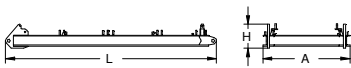
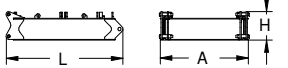
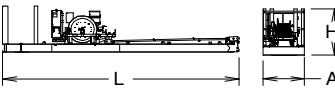
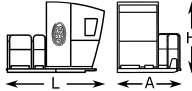
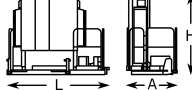
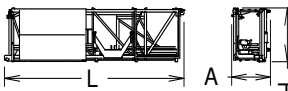

LISTA DE EMBARQUE / PACKING LIST

J390



			L (ft)	A (ft)	H (ft)	P/W (lb)
Contrapluma / Counterjib	C0-19		15.6	6.4	1.7	5630
	C1-19		8.3	6.3	1.9	2120
Contrapluma con mecanismos (sin cable) + plúmín auxiliar + armario eléctrico / Counterjib with mechanism (without rope) + auxiliary jib + electrical cabinet	C2-12		39.4	6.9	7.7	18960
Plataforma y cabina / Platform and cabin			11.5	6.8	7.9	2390
Armario eléctrico y plataforma			9.0	5.3	8.1	2230
Transporte torre de montaje / Jacking cage transport	TM20L-5,6		31.3	6.8	8.3	12540
Contrapeso / Counterweight	Lastre / Ballast		12.5	1.9	4.9	13230
			12.5	0.9	4.9	6600
			12.5	0.6	4.9	4400

TREPADO / CLIMBING

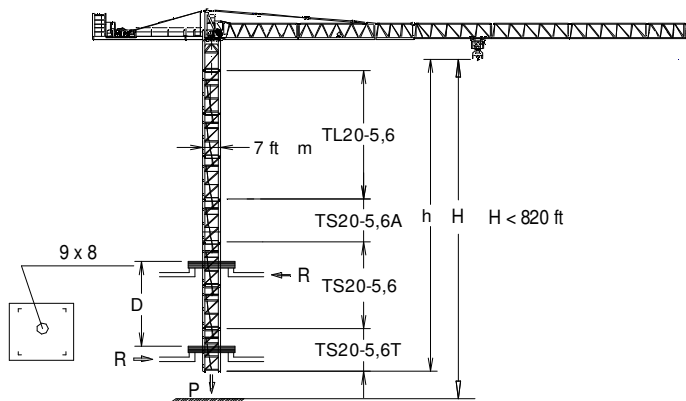
J390



h_{max} :
TS20-5,6T + 3xTS20-5,6 + TS20-5,6A + 4xTL20-5,6

		
98 ft		
h (ft)	152	
D (ft)	56 – 71	
P (lbf)	272000	218100
Rmax (lbf)	46800	103400
TS20-5,6T: 160.32.600		

i Trepado interno / Internal climbing

 **FEM 1005 - C25**



Reservado el derecho a modificaciones sin previo aviso. Declinamos toda responsabilidad derivada de la información proporcionada / Subject to modification, without prior notice. This information is supplied without liability

24/01/2024

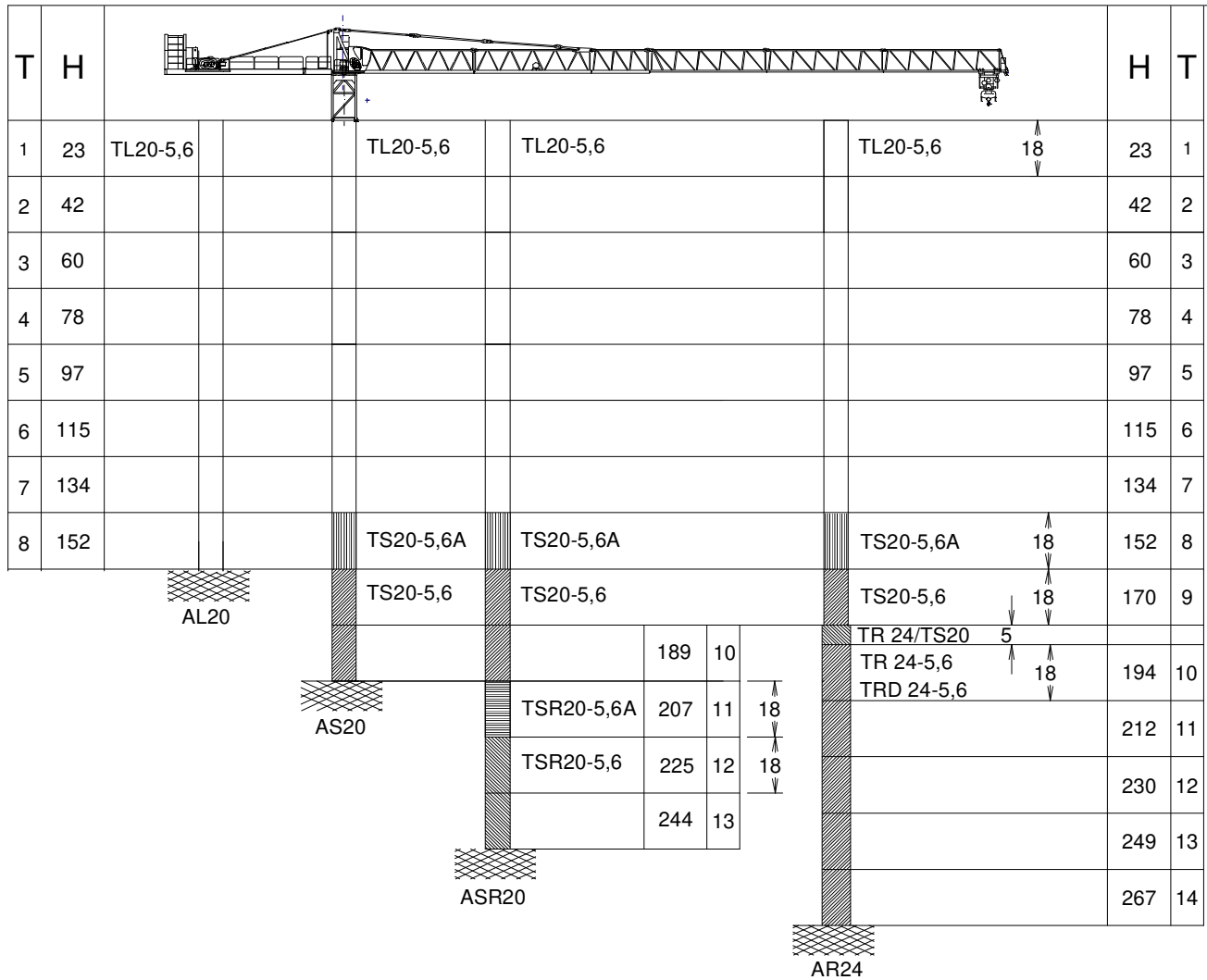

T : Torre / Tower
H : Altura / Height

Otras configuraciones de torre / Other tower configuration

TRANSPORTE / TRANSPORT



$H = 8 \times TL20-5,6 + AL20 +$

10 x



11 x



Viento fuera de servicio / Out of service wind

Consultar / Consult

En servicio / In service

Fuera de servicio / Out of service



Ctra./ Rd. Madrid – Irún - Km. 415 - 20213 IDIAZABAL (Gipuzkoa) - ESPAÑA / SPAIN
P.O. Box, 23 - 20.200 - BEASAIN - E-mail: jaso@jaso.com
Tel. +34 943 - 18 70 00 • Fax. +34 943 - 18 70 20
www.jaso.com

24/01/2024

FEM 1005 - C25

DELEGACIÓN / DEALER