



# J235.12

EN 14439  
C25

**GRUA TORRE / TOWER CRANE**  
GRUE A TOUR / TURMDREHKRAN / БАШЕННЫЙ КРАН / رافعة برجية

FEM 1005 - C25

UNE-EN-ISO 9001

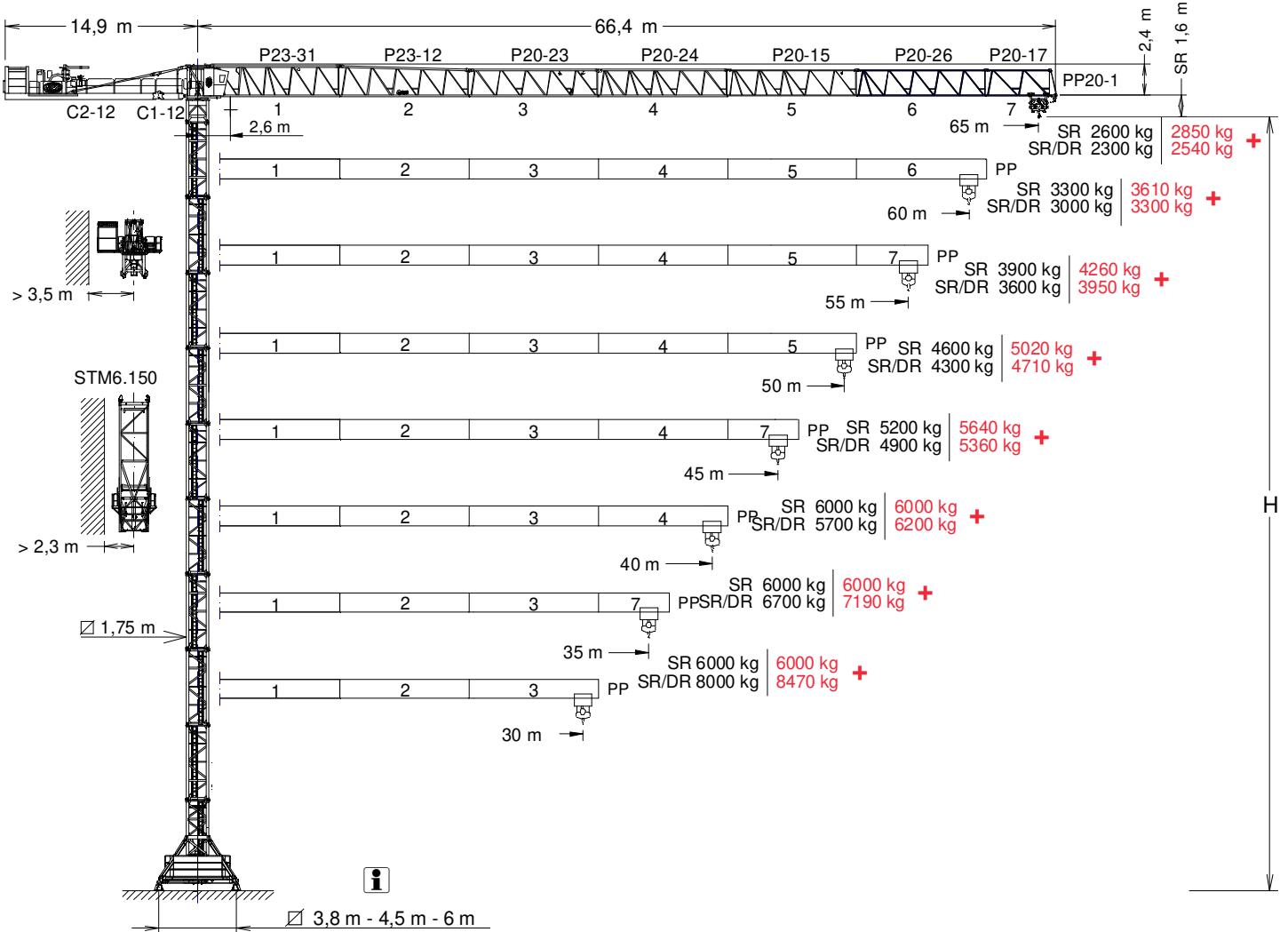

\*OPTIONAL EXTRA LIFT

C2-12	171.50.200
C1-12	171.50.050
P23-31	171.40.700
P23-12	171.41.000

P20-23	171.42.300
P20-24	171.43.200
P20-15	171.44.000
P20-26	171.45.200

P20-17	171.46.000
PP20-1	171.47.000
T3-150	161.32.000

T6-150	161.31.000
TD6-150	161.31.700
T12-150	161.31.500

## CUSTOMIZE YOUR CRANE

## OPTIMUS line

EXTRA Lift	OPTI Cube	TC Diagnosis SYSTEM	CLIMBING Solution	SAFETY Pack	Customization	ECO Mode	COMFORT Cabin	HIGH POWER Motors	JL25 Tower Crane Elevator	SMARTLINK BE SMART keep control



Reservado el derecho a modificaciones sin previo aviso. Declinamos toda responsabilidad derivada de la información proporcionada / Subject to modification, without prior notice. This information is supplied without liability / L'entreprise se réserve le droit de procéder à des modifications sans préavis. Nous déclinons toute responsabilité quant aux informations fournies / Das Recht auf Änderungen ohne vorherige Ankündigung bleibt vorbehalten. Wir übernehmen keine Gewähr für die gemachten Angaben / Мы оставляем за собой право на внесение изменений без предварительного уведомления. Мы снимаем с себя любую ответственность в отношении предоставленной информации / حقوق التغيير محفوظة دون إشعار مسبق. دون أدنى مسؤولية عن المعلومات المقدمة

29/11/2024

SR

(HSR) ESTACIONARIA 1 / STATIONARY 1 / STATIONAIRE 1 / STATIONÄR 1 / СТАЦИОНАРНОЕ СОСТОЯНИЕ / ثابتة

▽▽	H(m)	☒	☐
65 - 30	47,2	8	-

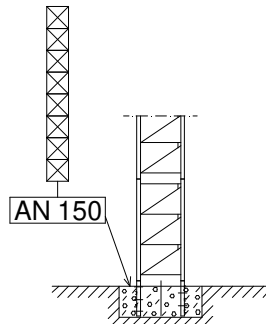

(HSR) ESTACIONARIA 3 / STATIONARY 3 / STATIONAIRE 3 / STATIONÄR 3 / СТАЦИОНАРНОЕ СОСТОЯНИЕ / ثابتة

▽▽	H(m)	☒	☐
65 - 60	42,3	6	-
55 - 30	39,4	5	1

▽▽	H(m)	☒	☐
65 - 30	51,0	7	1

▽▽	H(m)	☒	☐
65 - 60	39,8	6	1
55 - 40	34,0	5	1
35 - 30	36,9	6	-

▽▽	H(m)	☒	☐
65 - 30	45,7	7	1

▽▽	H(m)	☐	☐	☒	☐
65 - 30	55,3	1	1	7	1

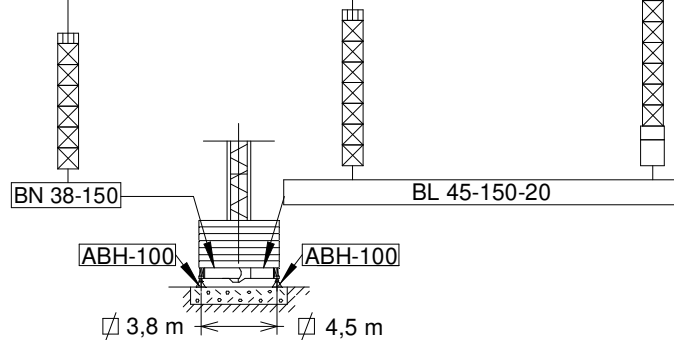
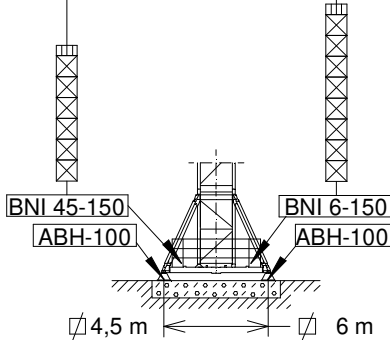

(HSR) TRASLACIÓN / TRAVELLING / TRASLATION / FORTBEWEGUNG / ПЕРЕМЕЩЕНИЕ / متحركة

▽▽	H(m)	☒	☐
65 - 60	42,5	6	-
55 - 30	39,6	5	1

▽▽	H(m)	☒	☐
65 - 30	51,2	7	1

▽▽	H(m)	☒	☐
65 - 60	40,0	6	1
55 - 40	34,2	5	1
35 - 30	37,1	6	-

▽▽	H(m)	☒	☐
65 - 30	45,9	7	1

▽▽	H(m)	☐	☐	☒	☐
65 - 30	55,5	1	1	7	1

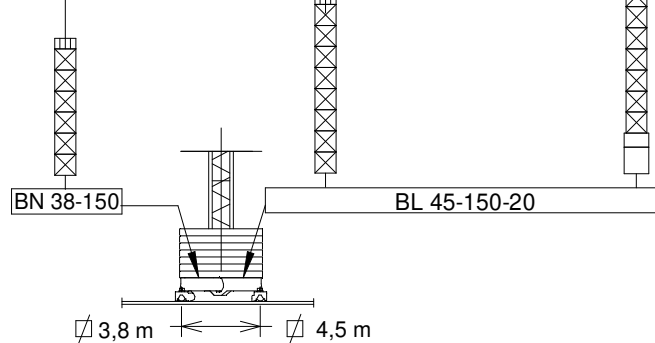
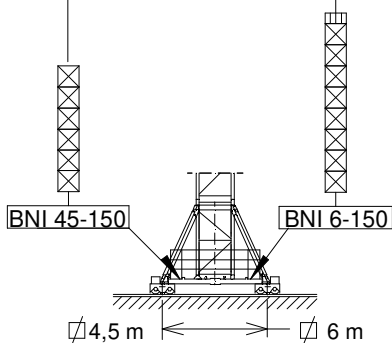

☐ T3-150

☒ T6-150  
TD6-150

☒ T12-150

☐ TL20/T6-150

☐ TL20-5,6



HSR/DR = HSR-0,5



HSR = Altura máxima bajo gancho sin arriostrar (m) / Maximum height under hook without fastening (m) / Hauteur maximale sous crochet sans ancrage (m)  
Max. Hakenhöhe ohne Verstreben (m) / Максимальная высота под крюком без крепления (m) / أقصى ارتفاع تحت الخطاف بدون ربط (m)

BNI 45-150 ..... 161.20.500  
BNI 6-150 ..... 161.20.000

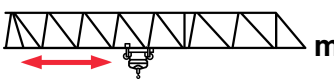
BN 38-150 ..... 161.20.800  
BL 45-150-20 ..... 171.20.200

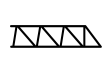
AN 150 ..... 161.21.000  
ABH 100 ..... 201.23.000

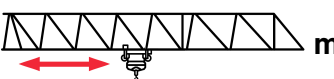
 <b>SR - 6 t</b>		 m										 EXTRA Lift
 6 t @ ... (m)	25	30	35	40	45	50	55	60	65			
65	31,3	6	6	5,30	4,57	4,0	3,55	3,17	2,86	2,60		
	33,7	6	6	5,76	4,97	4,36	3,87	3,47	3,13	2,85	+	
60	35,3	6	6	6	5,23	4,58	4,07	3,65	3,30	—		
	38,0	6	6	6	5,67	4,99	4,44	3,99	3,61	—	+	
55	37,4	6	6	6	5,57	4,89	4,35	3,90	—	—		
	40,3	6	6	6	6	5,32	4,74	4,26	—	—	+	
50	39,3	6	6	6	5,89	5,17	4,60	—	—	—		
	42,4	6	6	6	6	5,63	5,02	—	—	—	+	
45	39,5	6	6	6	5,92	5,20	—	—	—	—		
	42,6	6	6	6	6	5,64	—	—	—	—	+	
40	40,0	6	6	6	6	—	—	—	—	—		
	40,0	6	6	6	6	—	—	—	—	—	+	
35	35,0	6	6	6	—	—	—	—	—	—		
	35,0	6	6	6	—	—	—	—	—	—	+	
30	30,0	6	6	—	—	—	—	—	—	—		
	30,0	6	6	—	—	—	—	—	—	—	+	

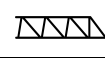
 <b>SR / DR - 6 / 12 t</b>		 m											 EXTRA Lift
 6 - 12 t @ ... (m)	15	20	25	30	35	40	45	50	55	60	65		
65	29,6 - 15,7	6 - 12	6 - 9,25	6 - 7,24	5,91	4,95	4,23	3,67	3,23	2,86	2,56	2,30	
	31,2 - 16,4	6 - 12	6 - 9,72	6 - 7,65	6 - 6,26	5,28	4,54	3,96	3,50	3,12	2,81	2,54	+
60	33,5 - 17,8	6 - 12	6 - 10,58	6 - 8,31	6 - 6,79	5,71	4,90	4,26	3,76	3,35	3,00	—	
	35,4 - 18,5	6 - 12	6 - 11,06	6 - 8,73	6 - 7,18	6 - 6,07	5,24	4,59	4,08	3,65	3,30	—	+
55	35,6 - 18,9	6 - 12	6 - 11,28	6 - 8,87	6 - 7,26	6 - 6,11	5,25	4,58	4,04	3,60	—	—	
	37,8 - 19,7	6 - 12	6 - 11,81	6 - 9,34	6 - 7,69	6 - 6,52	5,64	4,95	4,40	3,95	—	—	+
50	37,5 - 19,9	6 - 12	6 - 11,94	6 - 9,39	6 - 7,69	6 - 6,48	5,57	4,87	4,30	—	—	—	
	40,1 - 20,8	6 - 12	6 - 12	6 - 9,90	6 - 8,17	6 - 6,94	6 - 6,01	5,29	4,71	—	—	—	+
45	37,7 - 20,0	6 - 12	6 - 12	6 - 9,45	6 - 7,75	6 - 6,53	5,61	4,90	—	—	—	—	
	40,5 - 20,9	6 - 12	6 - 12	6 - 9,97	6 - 8,24	6 - 7,01	6 - 6,08	5,36	—	—	—	—	+
40	38,2 - 20,3	6 - 12	6 - 12	6 - 9,59	6 - 7,86	6 - 6,63	5,70	—	—	—	—	—	
	40,0 - 21,2	6 - 12	6 - 12	6 - 10,12	6 - 8,38	6 - 7,13	6 - 6,20	—	—	—	—	—	+
35	35,0 - 20,5	6 - 12	6 - 12	6 - 9,70	6 - 7,95	6 - 6,70	—	—	—	—	—	—	
	35,0 - 21,4	6 - 12	6 - 12	6 - 10,22	6 - 8,45	6 - 7,19	—	—	—	—	—	—	+
30	30,0 - 20,6	6 - 12	6 - 12	6 - 9,76	6 - 8	—	—	—	—	—	—	—	
	30,0 - 21,5	6 - 12	6 - 12	6 - 10,26	6 - 8,47	—	—	—	—	—	—	—	+

Datos válidos para / Valid data for  
 Donnees valables pour / Gultige Daten für / Допустимые данные для / البيانات الصالحة ل

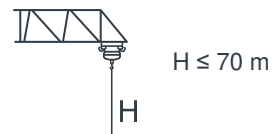



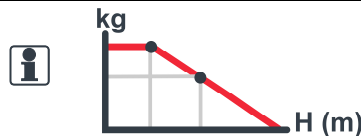

<b>EC60125VF</b> 44,1 kW	<b>*EC60152VF</b> 45 kW	<b>*EC88225VF</b> 65 kW
<p>6 t ... 38 m/min 0,9 t ... 126 m/min</p>	<p>6 t ... 38 m/min 1 t ... 152 m/min</p>	<p>6 t ... 54 m/min 1,1 t ... 225 m/min</p>
<p>12 t ... 19 m/min 1,8 t ... 63 m/min</p>	<p>12 t ... 19 m/min 2 t ... 76 m/min</p>	<p>12 t ... 27 m/min 2,2 t ... 112 m/min</p>
<p><math>H \leq</math> SR 266 m DR 133 m</p>	<p><math>H \leq</math> SR 534 m DR 267 m</p>	
<p>702 m</p>	<p>1378 m</p>	



<b>OG1507VF</b> 2 x 5,5 kW	<b>TC770VF</b> 5,5 kW	<b>TG2020VF</b> 2 x 7,3 kW	<b>TH1506</b> 11 kW
0...0,8 r/min sl/min	6 t 0...70 m/min 12 t 0...35 m/min	0...20 m/min	1 m/min

3~ 400V 50Hz  
480V 60Hz

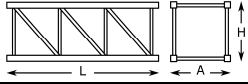
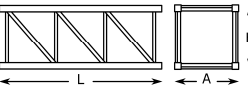
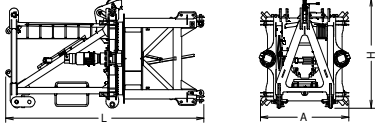
KVA			
EC60125VF	46	58	71
EC60152VF	46	58	71
EC88225VF	51	67	82

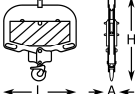
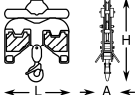
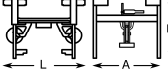
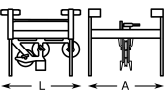
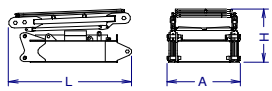
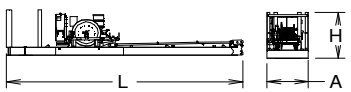
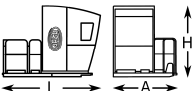
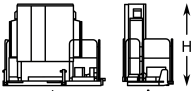
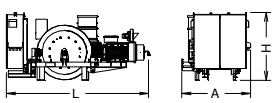
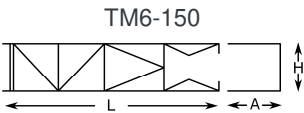
		L (m)	A (m)	H (m)	P/W(kg)	
<b>Torre inferior / Lower tower</b> Tour inférieure / Unterer Turm البرج السفلي / Нижняя башня	TI-6-150		6,175	2,190	2,190	3535
<b>Torre / Tower</b> Tour / Turm / Башня / برج	T6-150		6,175	1,870	1,870	2760
	TD6-150		6,175	1,870	1,870	2930
	T3-150		3,265	1,870	1,870	1550
	T12-150		12,000	1,870	1,870	5180
<b>Torre asiento pista + punta de torre + orientación</b> <b>Slewing table + tower head + slewing mechanism</b> Tour pivot + porte-flèche + mécanisme d'orientation Turmsitz + Turmspitze + Ausrichtung Сиденье площадки + верхней секции башни + поворотный механизм برج وحدة الدوارن + رأس البرج + آلية الدوران			4,630	2,080	2,490	6750
<b>Tramo de pluma</b> <b>Jib section</b> Tronçon de flèche Auslegerabschnitt Секция стрелы أجزاء الذراع	P23-31		10,280	1,356	2,495	2620
	P23-12+tr		10,280	1,126	2,475	2570
	P20-23		10,235	1,126	2,215	1690
	P20-24		10,190	1,126	2,195	1205
	P20-15		10,190	1,126	2,155	815
	P20-26		10,190	1,126	2,215	585
	P20-17		5,180	1,126	2,215	350
	PP20-1		0,890	1,290	2,500	130
<b>Polipasto / Hook assembly</b> Palan / Flaschenzug Полиспаст / بكرة	SR		0,860	0,200	1,126	220
	SR / DR		1,020	0,390	1,324	390
<b>Carro / Trolley</b> Chariot / Laufkatze Грузовая тележка / عرب	SR		1,560	1,935	1,891	320
	SR / DR		1,753	1,960	1,860	400
<b>Contrapluma / Counterjib</b> Contre-flèche / Gegenausleger Противовесная консоль / الذراع المعاكس	C1-12		2,398	1,430	1,100	1080
	C2-12		11,982	2,106	2,500	9245
<b>Plataforma y cabina / Platform and cabin</b> Plateforme et cabine / Plattform + Führerstand Платформа и кабина / منصة وكابينة			3,520	2,060	2,400	1120
<b>Armario eléctrico y plataforma</b> Electrical cabinet and platform / Armoire électrique et plateforme / Stromkasten + Plattform / الخزانة الكهربائية والمنصة			2,655	1,317	2,339	821
<b>Soporte y elevación (sin cable) / Support and hoisting (without rope)</b> Support et levage (sans câble) / Unterstützung und Hebewerk (ohne Seil) Опора и подъем (без троса) / دعم ورفع (بدون كابل)			3,800	1,840	1,840	3710
<b>Estructura torre de montaje / Jacking cage structure</b> Structure de tour de montage / Konstruktion des Montageturms / Структура монтажной башни	TM6-150		10,320	2,420	2,310	3500

# COMPOSICIONES DE TORRE / TOWER COMPOSITIONS

J235.12

COMPOSITIONS DE LA TOUR / TURMZUSAMMENSETZUNGEN / КОНСТРУКЦИЯ БАШНИ / مكونات البرج

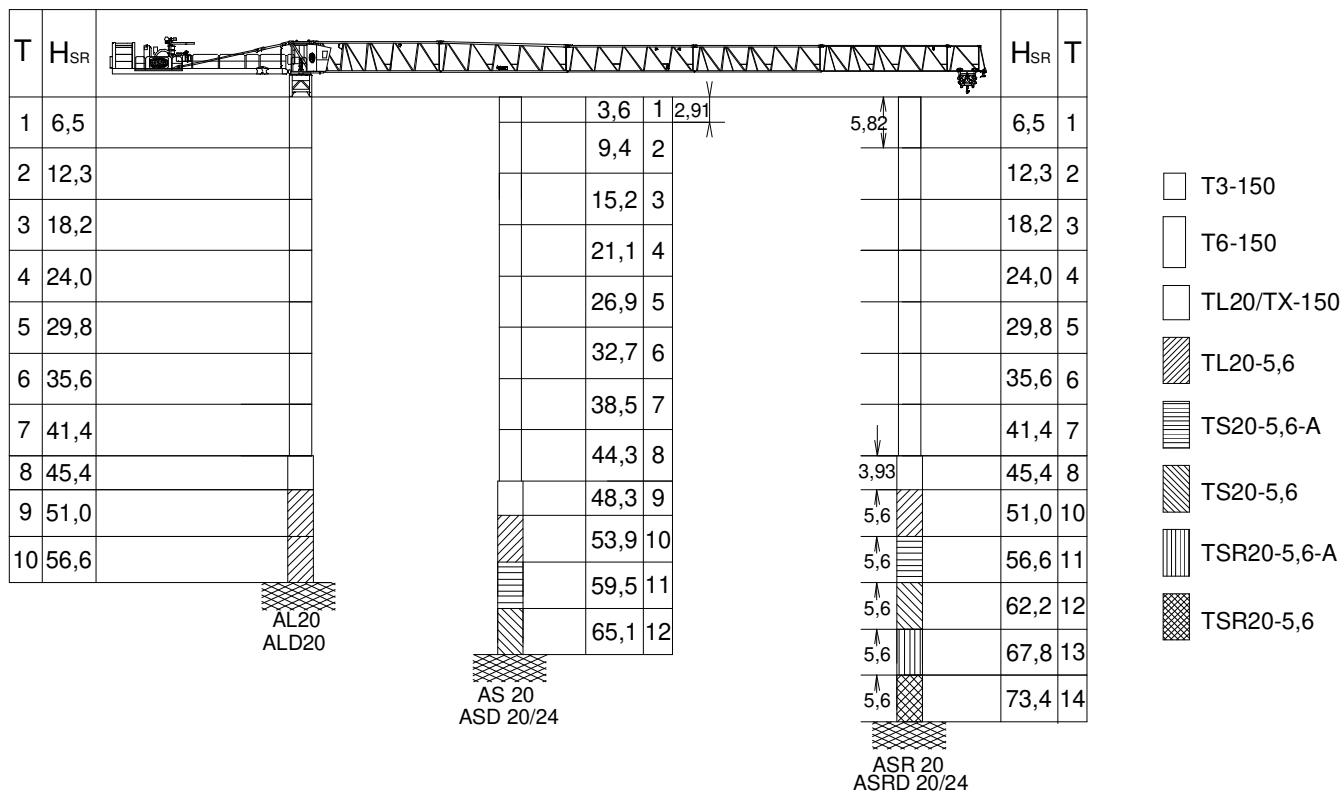

T: Torre / Tower / Tour / Turm / Башни / أبراج  
H: Altura / Height / Hauteur / Höhe / Высота / ارتفاع

$$H_{SR/DR} = H_{SR} - 0,5$$

TL20/TX-150.....	161.36.000	AL 20.....	153.21.800
TL20-5,6.....	204.31.400	ALD 20.....	160.21.250
TS20-5,6A.....	204.31.500	AS 20.....	160.21.010
TS20-5,6.....	204.31.200	ASD 20/24.....	160.21.080
TSR20-5,6A.....	206.31.300	ASR 20.....	160.21.200
TSR20-5,6.....	206.31.000	ASRD 20/24.....	156.21.000

**i** Otras configuraciones de torre / Other tower configuration / Autres configurations / Andere turmkonfigurationen / Прочие конфигурации / مكونات أخرى

## TRANSPORTE / TRANSPORT / TRANSPORT / TRANSPORT / ТРАНСПОРТИРОВКА / نقل

J235.12



**i** Viento fuera de servicio / Out of service wind / Vitesse du vent hors service / Wind außer betrieb / Ветровая нагрузка в покое / الريح خارج الخدمة

**i** Consultar / Consult / Nous consulter / Anfragen / Консультируйтесь / الرجوع إلى

**▶** En servicio / In service / En service / In betrieb / В работе / في الخدمة

**■** Fuera de servicio / Out of service / Hors service / Außer betrieb / В покое / خارج الخدمة

**\*** Opcional / Optional / En option / Optional / Опция / اختياري



Ctra./ Rd. Madrid – Irún - Km. 415 - 20213 IDIAZABAL (Gipuzkoa) - ESPAÑA / SPAIN  
P.O. Box, 23 - 20.200 - BEASAIN - E-mail: jaso@jaso.com  
Tel. +34 943 - 18 70 00 • Fax. +34 943 - 18 70 20  
[www.jaso.com](http://www.jaso.com)

29/11/2024

**FEM 1005 - C25**

DELEGACIÓN / DEALER

Reservado el derecho a modificaciones sin previo aviso. Declinamos toda responsabilidad derivada de la información proporcionada / Subject to modification, without prior notice. This information is supplied without liability / L'entreprise se réserve le droit de procéder à des modifications sans préavis. Nous déclinons toute responsabilité quant aux informations fournies / Das Recht auf Änderungen ohne vorherige Ankündigung bleibt vorbehalten. Wir übernehmen keine Gewähr für die gemachten Angaben / Мы оставляем за собой право на внесение изменений без предварительного уведомления. Мы снимаем с себя любую ответственность в отношении предоставленной информации / حقوق التغيير محفوظة دون إشعار مسبق. دون أدنى مسؤولية عن المعلومات المقدمة