



# J118HPA

EN 14439  
C25

**GRUA TORRE / TOWER CRANE**  
GRUE A TOUR / TURMDREHKRAN / БАШЕННЫЙ КРАН / رافعة برجية

FEM 1005 - C25

UNE-EN-ISO 9001

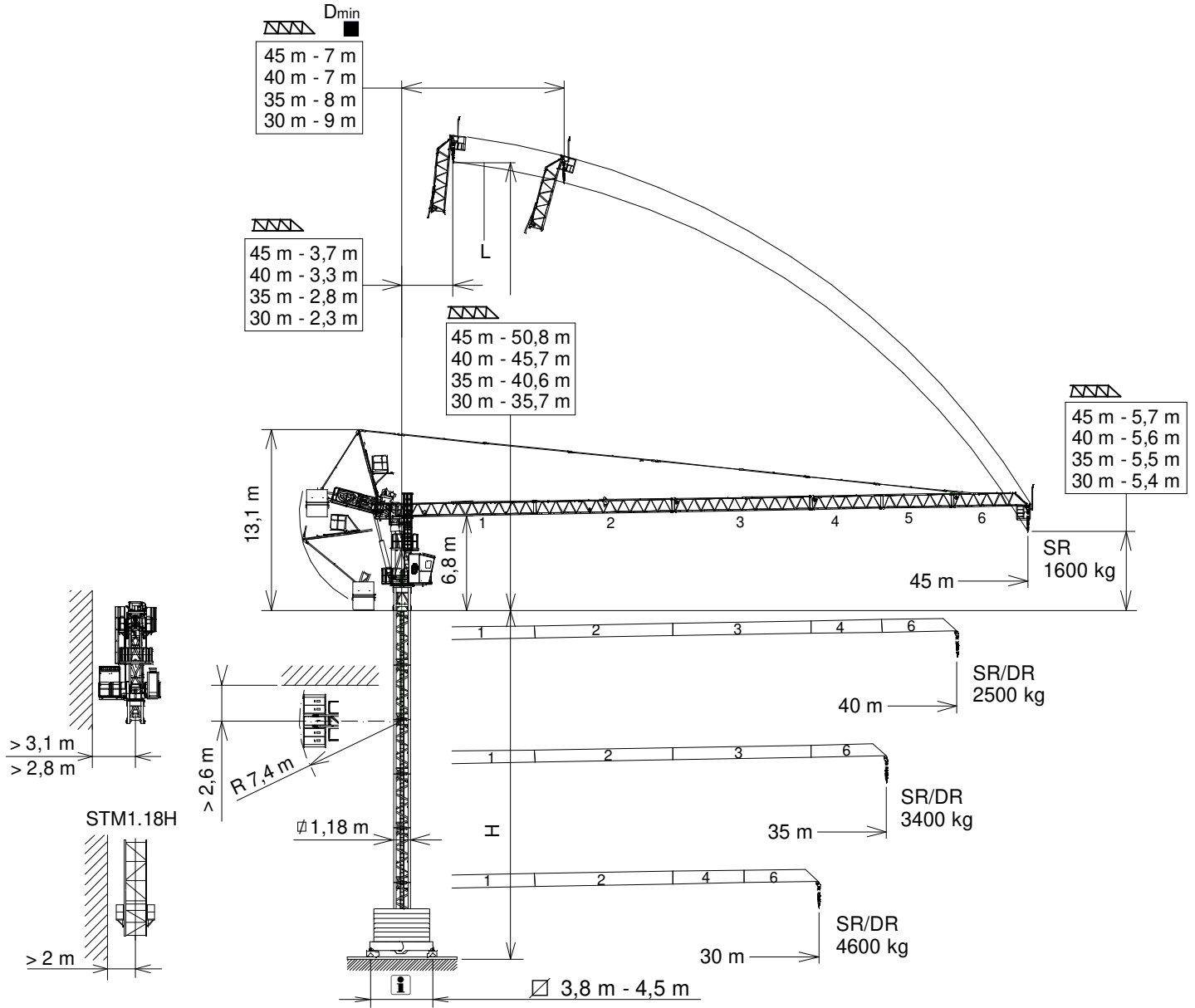

H= Máxima altura de torre sin arriostrar (m). / Maximum tower height without fastening (m). / Hauteur maximale de tour sans ancrage (m). / Maximale Höhe ohne Verstreben (m) / Максимальная высота башни без крепления (М). / أقصى ارتفاع للبرج بدون ربط (م) /

D ■ Distancias fuera de servicio dependen de la altura de la torre / Out of service distances depend on tower height / Distances hors service dépendent de la hauteur de la tour / Die Außerbetriebnahmereichweiten hängen von der Höhe des Turms ab

## CUSTOMIZE YOUR CRANE

OPTIMUS  
line JASD



OPTI Cube



TC Diagnosis SYSTEM



CLIMBING Solution



SAFETY Pack



Customization



COMFORT Cabin



HIGH POWER Motors



JL25 Tower Crane Elevator



Reservado el derecho a modificaciones sin previo aviso. Declinamos toda responsabilidad derivada de la información proporcionada / Subject to modification, without prior notice. This information is supplied without liability / L'entreprise se réserve le droit de procéder à des modifications sans préavis. Nous déclinons toute responsabilité quant aux informations fournies / Das Recht auf Änderungen ohne vorherige Ankündigung bleibt vorbehalten. Wir übernehmen keine Gewähr für die gemachten Angaben / Мы оставляем за собой право на внесение изменений без предварительного уведомления. Мы снимаем с себя любую ответственность в отношении предоставленной информации / حقوق التغيير محفوظة دون إشعار مسبق. دون أدنى مسؤولية عن المعلومات المقدمة /

(H) ESTACIONARIA 1 / STATIONARY 1 / STATIONAIRE 1 / STATIONÄR 1 / СТАЦИОНАРНОЕ СОСТОЯНИЕ / ثابتة

H(D■)				H(Dmin■)																																											
<table border="1"> <thead> <tr> <th>▽▽</th> <th>D■ (m)</th> <th>H(m)</th> <th>☒</th> </tr> </thead> <tbody> <tr><td>30</td><td>9</td><td>31,6</td><td>8</td></tr> <tr><td>35</td><td>16</td><td>31,6</td><td>8</td></tr> <tr><td>40</td><td>23</td><td>31,6</td><td>8</td></tr> <tr><td>45</td><td>18</td><td>27,1</td><td>7</td></tr> </tbody> </table>				▽▽	D■ (m)	H(m)	☒	30	9	31,6	8	35	16	31,6	8	40	23	31,6	8	45	18	27,1	7	<table border="1"> <thead> <tr> <th>▽▽</th> <th>D■ (m)</th> <th>H(m)</th> <th>☒</th> </tr> </thead> <tbody> <tr><td>30</td><td>9</td><td>31,6</td><td>8</td></tr> <tr><td>35</td><td>8</td><td>27,7</td><td>7</td></tr> <tr><td>40</td><td>7</td><td>23,7</td><td>6</td></tr> <tr><td>45</td><td>7</td><td>23,7</td><td>6</td></tr> </tbody> </table>				▽▽	D■ (m)	H(m)	☒	30	9	31,6	8	35	8	27,7	7	40	7	23,7	6	45	7	23,7	6
▽▽	D■ (m)	H(m)	☒																																												
30	9	31,6	8																																												
35	16	31,6	8																																												
40	23	31,6	8																																												
45	18	27,1	7																																												
▽▽	D■ (m)	H(m)	☒																																												
30	9	31,6	8																																												
35	8	27,7	7																																												
40	7	23,7	6																																												
45	7	23,7	6																																												

(H) ESTACIONARIA 3 / STATIONARY 3 / STATIONAIRE 3 / STATIONÄR 3 / СТАЦИОНАРНОЕ СОСТОЯНИЕ / ثابتة

H(D■)				H(Dmin■)																																											
<table border="1"> <thead> <tr> <th>▽▽</th> <th>D■ (m)</th> <th>H(m)</th> <th>☒</th> </tr> </thead> <tbody> <tr><td>30</td><td>9</td><td>32,8</td><td>8</td></tr> <tr><td>35</td><td>16</td><td>32,8</td><td>8</td></tr> <tr><td>40</td><td>23</td><td>32,8</td><td>8</td></tr> <tr><td>45</td><td>18</td><td>28,9</td><td>7</td></tr> </tbody> </table>				▽▽	D■ (m)	H(m)	☒	30	9	32,8	8	35	16	32,8	8	40	23	32,8	8	45	18	28,9	7	<table border="1"> <thead> <tr> <th>▽▽</th> <th>D■ (m)</th> <th>H(m)</th> <th>☒</th> </tr> </thead> <tbody> <tr><td>30</td><td>15</td><td>28,9</td><td>7</td></tr> <tr><td>35</td><td>18</td><td>28,9</td><td>7</td></tr> <tr><td>40</td><td>15</td><td>25</td><td>6</td></tr> <tr><td>45</td><td>20</td><td>25</td><td>6</td></tr> </tbody> </table>				▽▽	D■ (m)	H(m)	☒	30	15	28,9	7	35	18	28,9	7	40	15	25	6	45	20	25	6
▽▽	D■ (m)	H(m)	☒																																												
30	9	32,8	8																																												
35	16	32,8	8																																												
40	23	32,8	8																																												
45	18	28,9	7																																												
▽▽	D■ (m)	H(m)	☒																																												
30	15	28,9	7																																												
35	18	28,9	7																																												
40	15	25	6																																												
45	20	25	6																																												
<table border="1"> <thead> <tr> <th>▽▽</th> <th>D■ (m)</th> <th>H(m)</th> <th>☒</th> </tr> </thead> <tbody> <tr><td>30</td><td>9</td><td>32,8</td><td>8</td></tr> <tr><td>35</td><td>8</td><td>28,9</td><td>7</td></tr> <tr><td>40</td><td>7</td><td>25</td><td>6</td></tr> <tr><td>45</td><td>7</td><td>25</td><td>6</td></tr> </tbody> </table>				▽▽	D■ (m)	H(m)	☒	30	9	32,8	8	35	8	28,9	7	40	7	25	6	45	7	25	6	<table border="1"> <thead> <tr> <th>▽▽</th> <th>D■ (m)</th> <th>H(m)</th> <th>☒</th> </tr> </thead> <tbody> <tr><td>30</td><td>9</td><td>25</td><td>6</td></tr> <tr><td>35</td><td>8</td><td>25</td><td>6</td></tr> <tr><td>40</td><td>7</td><td>21</td><td>5</td></tr> <tr><td>45</td><td>7</td><td>21</td><td>5</td></tr> </tbody> </table>				▽▽	D■ (m)	H(m)	☒	30	9	25	6	35	8	25	6	40	7	21	5	45	7	21	5
▽▽	D■ (m)	H(m)	☒																																												
30	9	32,8	8																																												
35	8	28,9	7																																												
40	7	25	6																																												
45	7	25	6																																												
▽▽	D■ (m)	H(m)	☒																																												
30	9	25	6																																												
35	8	25	6																																												
40	7	21	5																																												
45	7	21	5																																												

(H) TRASLACIÓN / TRAVELLING / TRASLATION / FORTBEWEGUNG / ПЕРЕМЕЩЕНИЕ / متحركة

H(D■)				H(Dmin■)																																											
<table border="1"> <thead> <tr> <th>▽▽</th> <th>D■ (m)</th> <th>H(m)</th> <th>☒</th> </tr> </thead> <tbody> <tr><td>30</td><td>9</td><td>33</td><td>8</td></tr> <tr><td>35</td><td>16</td><td>33</td><td>8</td></tr> <tr><td>40</td><td>23</td><td>33</td><td>8</td></tr> <tr><td>45</td><td>18</td><td>29</td><td>7</td></tr> </tbody> </table>				▽▽	D■ (m)	H(m)	☒	30	9	33	8	35	16	33	8	40	23	33	8	45	18	29	7	<table border="1"> <thead> <tr> <th>▽▽</th> <th>D■ (m)</th> <th>H(m)</th> <th>☒</th> </tr> </thead> <tbody> <tr><td>30</td><td>15</td><td>29</td><td>7</td></tr> <tr><td>35</td><td>18</td><td>29</td><td>7</td></tr> <tr><td>40</td><td>15</td><td>25,1</td><td>6</td></tr> <tr><td>45</td><td>20</td><td>25,1</td><td>6</td></tr> </tbody> </table>				▽▽	D■ (m)	H(m)	☒	30	15	29	7	35	18	29	7	40	15	25,1	6	45	20	25,1	6
▽▽	D■ (m)	H(m)	☒																																												
30	9	33	8																																												
35	16	33	8																																												
40	23	33	8																																												
45	18	29	7																																												
▽▽	D■ (m)	H(m)	☒																																												
30	15	29	7																																												
35	18	29	7																																												
40	15	25,1	6																																												
45	20	25,1	6																																												
<table border="1"> <thead> <tr> <th>▽▽</th> <th>D■ (m)</th> <th>H(m)</th> <th>☒</th> </tr> </thead> <tbody> <tr><td>30</td><td>9</td><td>33</td><td>8</td></tr> <tr><td>35</td><td>8</td><td>29</td><td>7</td></tr> <tr><td>40</td><td>7</td><td>25,1</td><td>6</td></tr> <tr><td>45</td><td>7</td><td>25,1</td><td>6</td></tr> </tbody> </table>				▽▽	D■ (m)	H(m)	☒	30	9	33	8	35	8	29	7	40	7	25,1	6	45	7	25,1	6	<table border="1"> <thead> <tr> <th>▽▽</th> <th>D■ (m)</th> <th>H(m)</th> <th>☒</th> </tr> </thead> <tbody> <tr><td>30</td><td>9</td><td>25,1</td><td>6</td></tr> <tr><td>35</td><td>8</td><td>25,1</td><td>6</td></tr> <tr><td>40</td><td>7</td><td>21,2</td><td>5</td></tr> <tr><td>45</td><td>7</td><td>21,2</td><td>5</td></tr> </tbody> </table>				▽▽	D■ (m)	H(m)	☒	30	9	25,1	6	35	8	25,1	6	40	7	21,2	5	45	7	21,2	5
▽▽	D■ (m)	H(m)	☒																																												
30	9	33	8																																												
35	8	29	7																																												
40	7	25,1	6																																												
45	7	25,1	6																																												
▽▽	D■ (m)	H(m)	☒																																												
30	9	25,1	6																																												
35	8	25,1	6																																												
40	7	21,2	5																																												
45	7	21,2	5																																												

BTX 45/BEX 45..... 137.20.500  
 BTX 38R /BEX 38R..... 137.20.000

AR 12 ..... 137.21.000

ABH 75..... 152.23.000

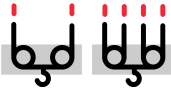

SR/DR



		SR 3.000 kg @...(m)	20	25	30	35	40	45
	DR 6.000 kg @...(m)							
45		33,1	3000	3000	3000	2780	2235	1600
40		37,3	3000	3000	3000	3000	2500	-
35	22,7	35	3000/6000	3000/5435	3000/4425	3000/3400	-	-
30	25,1	30	3000/6000	3000/6000	3000/4600	-	-	-
	DR 5.000 kg @...(m)	DR 2.500 kg @...(m)	20	25	30	35	40	
40	24,7	40	5000	4940	4030	3315	2500	

Datos válidos para / Valid data for  
Donnees valables pour / Gultige Daten für / Допустимые данные для / البيانات الصالحة لـ

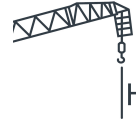

SR H ≤ 240 m  
DR H ≤ 120 m



**EC2556VF**  
18,4 kW

**\* EC3380VF**  
24,2 kW

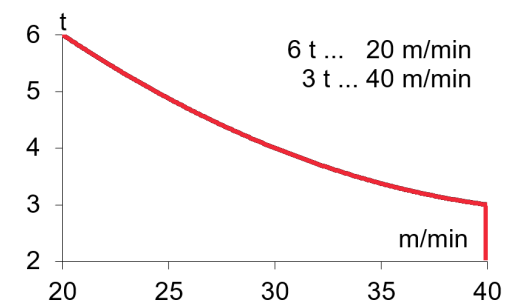
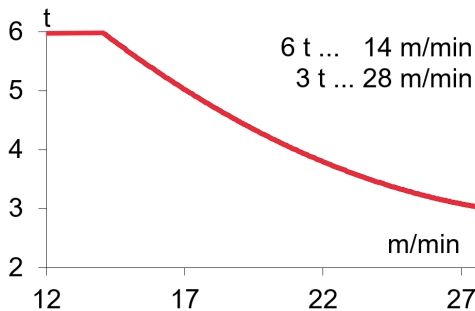
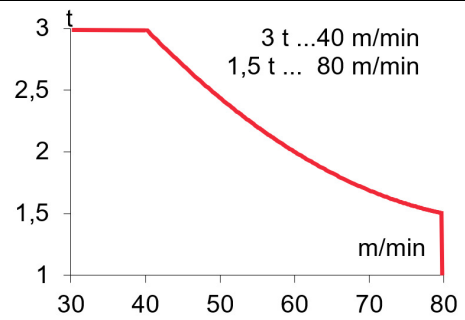
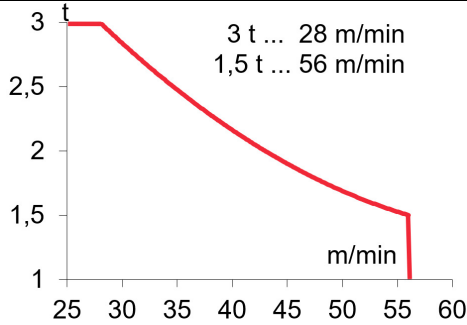

H ≤ SR 452 m  
DR 226 m



1181 m

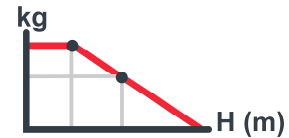

**OG708VF**  
5,5 kW

0...0,8  
r/min  
sl/min



**EPH2015VF**  
15 kW

1,5  
min



**TG825VF**  
2 x 3 kW

0...25  
m/min



**TH151**  
11 kW

1 m/min

⚡ 3~ 400V 50Hz  
480V 60Hz

**KVA**

<b>EC2556VF</b>	46
<b>EC3380VF</b>	52



H = 7 x TR 4R + AR 12 +

3 x



4 x

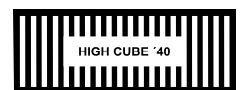





**FEM 1005 – C25**

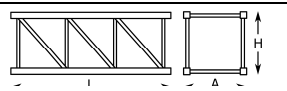
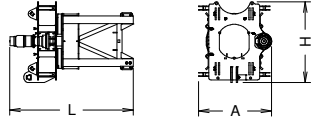
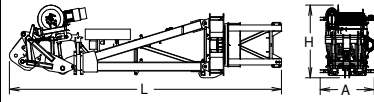
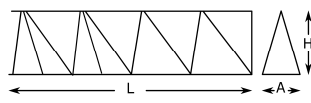
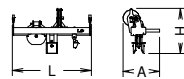
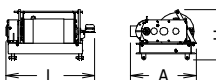
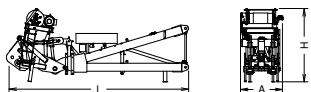
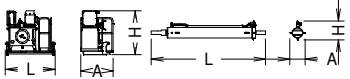
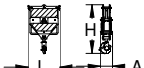

**LISTA DE EMBARQUE / PACKING LIST**

LISTE DE COLISAGE / KOLLI LISTE / СПИСОК ПОСТАВКИ / قائمة التحميل

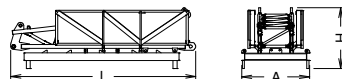
**J118HPA**

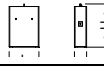
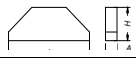
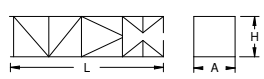
			L (m)	A (m)	H (m)	P/W(kg)
<b>Torre / Tower</b> Tour / Turm / Башня / برج	TR8RM TR12RM TR4R		8,070 12,010 4.150	1,190 1,190 1.190	1,190 1,190 1.190	2575 3715 1430
<b>Torre asiento pista + base punta de torre + orientación</b> <b>Slewing table + tower head base + slewing mechanism</b> Tour pivot + base du porte-flèche + mécanisme d'orientation Turmsitz + Turmspitzenbasis + Ausrichtung / Сиденье площадки + основание верхней секции башни + поворотный механизм / برج وحدة الدوران، قاعدة رأس البرج + آلية الد/			2,900	1,710	1,900	3000
<b>Conjunto asiento pista, punta de torre, orientación y elevación</b> <b>Slewing table assembly, tower head, slewing and hoisting mechanism</b> / Groupe pivot + porte-flèche + mécanisme d'orientation + de levage / Gruppe Turmsitz + Turmspitzenbasis + Ausrichtung + Hebewerk / Сиденье площадки + верхняя секция башни+ поворотный механизм подъемный механизм / مجموعة وحدة الدوران + رأس البرج + آلية الدوران			8,450	1,750	2,450	8000
<b>Tramo de pluma</b> <b>Jib section</b> Tronçon de flèche Auslegerabschnitt Секция стрелы أجزاء الذراع	1 2 3 4 5 6		10,230 10,165 10,155 5,265 5,265 5,705	0,990 0,860 0,860 0,860 0,845 0,865	1,075 1,065 1,050 1,050 1,045 1,057	1195 870 630 320 290 410
<b>Punta de pluma / Jib end</b> / Pointe de flèche / Auslegerspitze Конец стрелы / مقدمة الذراع			0,820	0,550	0,685	90
<b>Mecanismo elevación carga / Hoisting mechanism</b> Mécanisme de levage / Lasthubmechanismus подъемный механизм / آلية الرفع			1,430	1,060	0,800	810
<b>Punta de torre + Elevación carga / Tower head + hoisting mechanism</b> Porte-flèche + mécanisme de levage / Turmspitze + Lasthub / Верхняя секция башни + подъемный механизм / رأس البرج + آلية الرفع			6,100	1,500	2,455	5000
<b>Elevación pluma con plataforma / Luffing mech + platform</b> Relevage de flèche + plateforme / Lasthubmechanismus + Plattformen / Подъем стрелы + Платформа / رافع الذراع + كابينة			2,700 3,380	1,180 0,620	2,23 0,535	1130 1350
<b>Polipasto / Hook assembly</b> Palan / Flaschenzug / Полиспаст / بكرة			0,835	0,235	1,175	220
<b>Tirante sostén pluma / Jib support tie</b> Tirant de fleche / Haltestange Ausleger Растяжка поддержки / مشد دعامة الذراع			6,260	0,360	0,350	685
<b>Contrapluma con plataformas / Counterjib with platforms</b> Contre-flèche avec plateformes / Gegenausleger+Plattformen Противовесная консоль с платформами / الذراع المقابل مع المنصة			4,600	1,700	1,600	1900
<b>Parte superior / Top part</b> / Partie supérieur / Oberteil			5,500	1,260	0,650	750
<b>Plataforma y cabina / Platform and cabin</b> Plateforme et cabine / Plattform + Führerstand Платформа и кабина / منصة وكابينة			4,150	2,100	2,500	1200
<b>Contrapeso / Counterweight</b> / Contrepoids Gegengewicht / Противовес / اوزان معاكسة			1,486 1,486	0,600 0,600	2,125 0,905	4100 1650
<b>Lastre / Ballast</b> / Lest / Ballast / Балласт / ثقل			4,000	0,340	1,300	4100
<b>Estructura torre de montaje / Jacking cage structure</b> Structure de tour de montage / Konstruktion des Montageturms / Структура монтажной башни هيكل برج التركيب	TM 1.18H		7,14	1,76	1,71	3300

 **FEM 1005 – C25**



Reservado el derecho a modificaciones sin previo aviso. Declinamos toda responsabilidad derivada de la información proporcionada / Subject to modification, without prior notice. This information is supplied without liability. L'entreprise se réserve le droit de procéder à des modifications sans préavis. Nous déclinons toute responsabilité quant aux informations fournies / Das Recht auf Änderungen ohne vorherige Ankündigung bleibt vorbehalten. Wir übernehmen keine Gewähr für die gemachten Angaben / Мы оставляем за собой право на внесение изменений без предварительного уведомления. Мы снимаем с себя любую ответственность отнюди предоставленной информации / المقدمة من المعلومات عن دون أننى مسؤوليية عن المعلومات المقدمة / حقوق التغيير محفوظة دون إشعار مسبق.

# COMPOSICIONES DE TORRE / TOWER COMPOSITIONS

COMPOSITIONS DE LA TOUR / TURMZUSAMMENSETZUNGEN / КОНСТРУКЦИЯ БАШНИ / برج مكونات

J118HPA

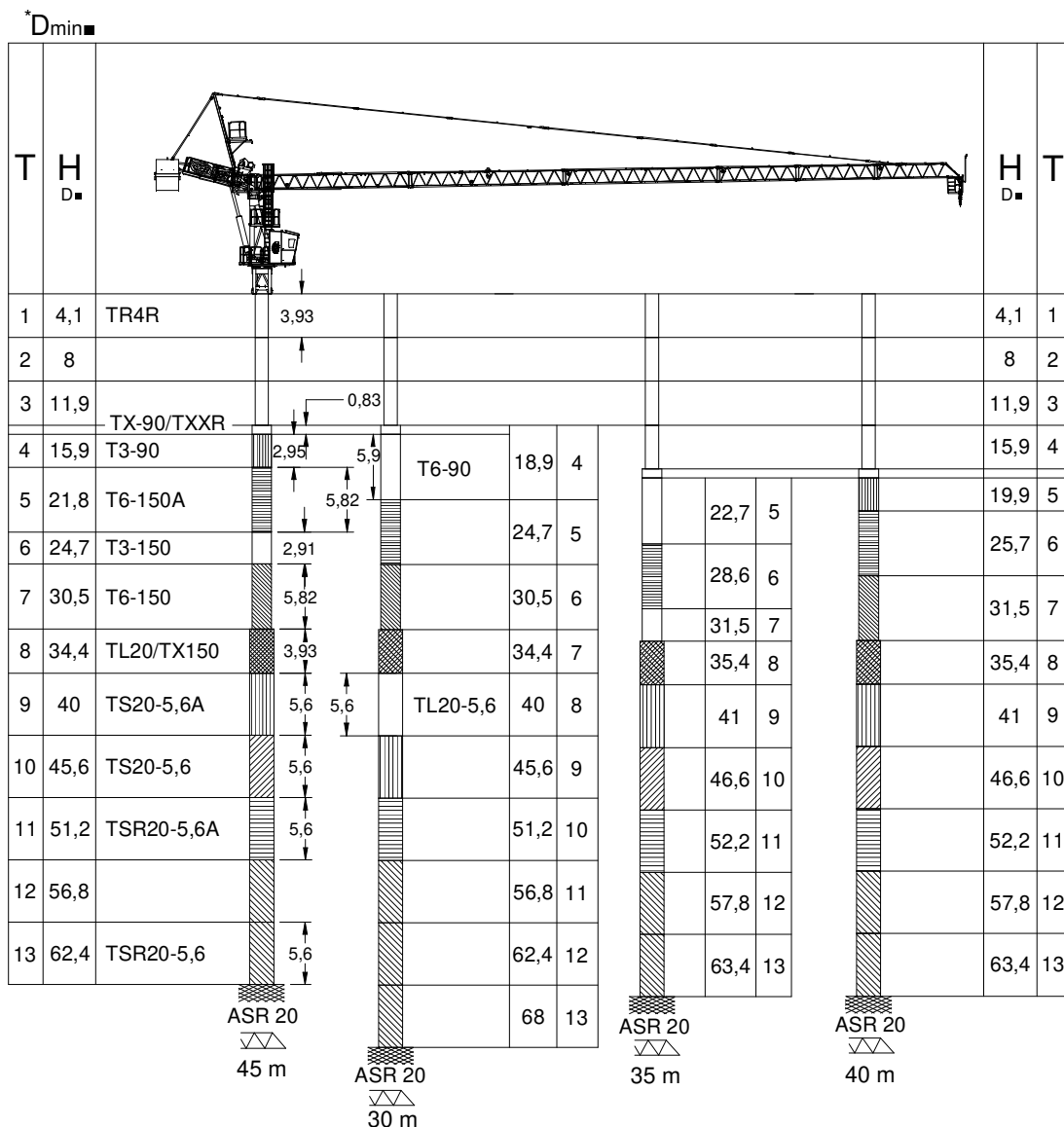

T : Torre / Tower / Tour / Turm / Башни / أبراج / ارتفاع  
 H : Altura / Height / Hauteur / Höhe / Высота / ارتفاع

TR4R.....	202.32.000	T6-150.....	161.31.000	TSR20-5,6A.....	206.31.300
TX-90/TXXR.....	202.36.500	TL20/TX-150.....	161.36.000	TSR20-5,6.....	206.31.000
T3-90.....	133.32.000	TL20-5,6.....	204.31.400	ASR 20.....	160.21.200
T6-150A.....	161.31.300	TS20-5,6A.....	204.31.500		
T3-150.....	161.32.000	TS20-5,6.....	204.31.200		

**Otras configuraciones de torre / Other tower configuration / Autres configurations / Andere turmkonfigurationen / Прочие конфигурации / مكونات أخرى**

**Viento fuera de servicio / Out of service wind / Vitesse du vent hors service / Wind außer betrieb / Ветровая нагрузка в покое / الريح خارج الخدمة**

**Consultar / Consult / Nous consulter / Anfragen / Консультируйтесь / الرجوع إلى**

**En servicio / In service / En service / In betrieb / В работе / في الخدمة**

**Fuera de servicio / Out of service / Hors service / Außer betrieb / В покое / خارج الخدمة**

**Opcional / Optional / En option / Optional / Опция / اختياري**



Ctra./ Rd. Madrid – Irún - Km. 415 - 20213 IDIAZABAL (Gipuzkoa) - ESPAÑA / SPAIN  
 P.O. Box, 23 - 20.200 - BEASAIN - E-mail: jaso@jaso.com  
 Tel. +34 943 - 18 70 00 • Fax. +34 943 - 18 70 20  
[www.jaso.com](http://www.jaso.com)

29/11/2024



FEM 1005-C25

DELEGACIÓN / DEALER

Reservado el derecho a modificaciones sin previo aviso. Declinamos toda responsabilidad derivada de la información proporcionada / Subject to modification, without prior notice. This information is supplied without liability / L'entreprise se réserve le droit de procéder à des modifications sans préavis. Nous déclinons toute responsabilité quant aux informations fournies / Das Recht auf Änderungen ohne vorherige Ankündigung bleibt vorbehalten. Wir übernehmen keine Gewähr für die gemachten Angaben / Мы оставляем за собой право на внесение изменений без предварительного уведомления. Мы снимаем с себя любую ответственность в отношении предоставленной информации / حقوق التغيير محفوظة دون إشعار مسبق. دون أدنى مسؤولية عن المعلومات المقدمة