



J780PA

UNE 58-101
FEM 1001

GRUA TORRE / TOWER CRANE
GRUE A TOUR / TURMDREHKRAN / БАШЕННЫЙ КРАН / رافعة برجية

FEM 1001

UNE-EN-ISO 9001

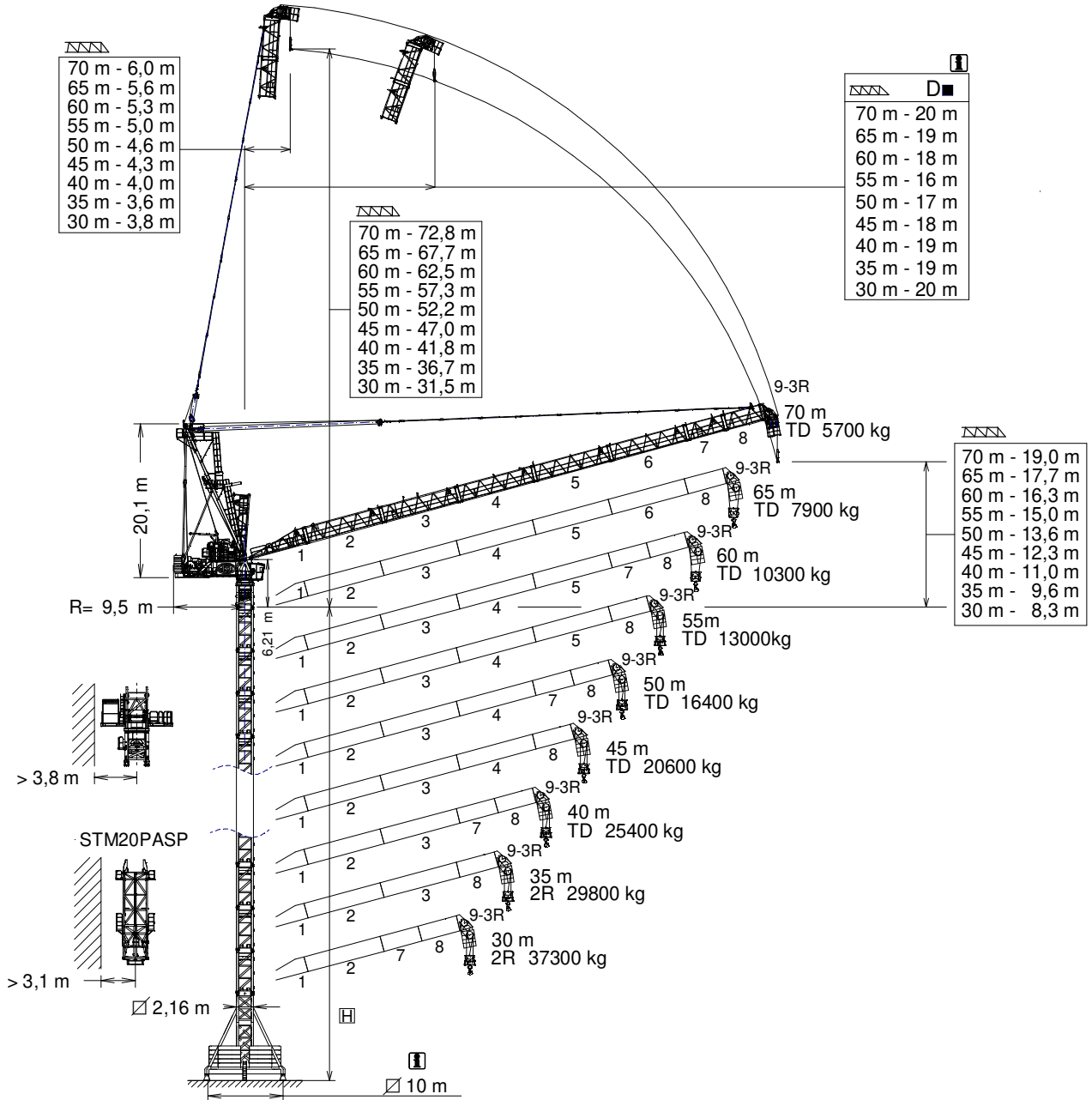

D ■ Distancias fuera de servicio dependen de la altura de la torre / Out of service distances depend on tower height / Distances hors service dépendent de la hauteur de la tour / Die Außerbetriebnahmereichweiten hängen von der Höhe des Turms ab

H= Máxima altura de torre sin arriostrar (m) / Maximum tower height without fastening (m)

Hauteur maximale de tour sans ancrage (m) / Maximale Höhe ohne Verstreben (m) / Максимальная высота башни без крепления (м) / أقصى ارتفاع للبرج بدون ربط (م)

* Tramo pluma / Jib section / Tronçon de fleche / Auslegerabschnitt / Секция стрелы / أجزاء الذراع

*Tramo pluma 1 / Jib section 1	214.40.000
*Tramo pluma 2 / Jib section 2	214.41.000
*Tramo pluma 3 / Jib section 3	214.42.000
*Tramo pluma 4 / Jib section 4	214.43.000
*Tramo pluma 5 / Jib section 5	214.44.000

*Tramo pluma 6 / Jib section 6	214.45.000
*Tramo pluma 7 / Jib section 7	214.46.000
*Tramo pluma 8 / Jib section 8	214.47.000
*Tramo pluma 9-3R / Jib section 9-3R	214.48.000

TSP20	214.31.300
TSP20-5,6	214.31.100
TSP24-5,6	214.32.200
TSP24/TSP20	212.36.000

CUSTOMIZE YOUR CRANE

OPTIMUS
line



OPTI Cube



TC Diagnosis SYSTEM



CLIMBING Solution



SAFETY Pack



Customization



ECO Mode



COMFORT Cabin



HIGH POWER Motors



JL25 Tower Crane Elevator



SMARTLINK
BE SMART keep control



Reservado el derecho a modificaciones sin previo aviso. Declinamos toda responsabilidad derivada de la información proporcionada / Subject to modification, without prior notice. This information is supplied without liability / L'entreprise se réserve le droit de procéder à des modifications sans préavis. Nous déclinons toute responsabilité quant aux informations fournies / Das Recht auf Änderungen ohne vorherige Ankündigung bleibt vorbehalten. Wir übernehmen keine Gewähr für die gemachten Angaben / Мы оставляем за собой право на внесение изменений без предварительного уведомления. Мы снимаем с себя любую ответственность в отношении предоставленной информации / حقوق التغيير محفوظة دون إشعار مسبق دون أدنى مسؤولية عن المعلومات المقدمة



TD
28 t

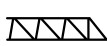

	TD @ ...(m)	25	30	35	40	45	50	55	60	65	70
70	37,0	28,0	28,0	28,0	24,5	19,6	15,7	12,5	9,9	7,6	5,7
65	37,0	28,0	28,0	28,0	24,5	19,7	15,9	12,7	10,1	7,9	-
60	37,0	28,0	28,0	28,0	24,5	19,8	16,0	12,9	10,3	-	-
55	37,0	28,0	28,0	28,0	24,6	19,9	16,1	13,0	-	-	-
50	37,2	28,0	28,0	28,0	24,8	20,1	16,4	-	-	-	-
45	37,6	28,0	28,0	28,0	25,3	20,6	-	-	-	-	-
40	37,7	28,0	28,0	28,0	25,4	-	-	-	-	-	-
35	35,0	28,0	28,0	28,0	-	-	-	-	-	-	-
30	30,0	28,0	28,0	-	-	-	-	-	-	-	-



2R
56 t

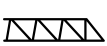

	2R @ ...(m)	@ ...(m)	20	25	30	35	40	45	50	55	60	65
65	42,0	27,0	42,0	42,0	35,9	28,1	22,3	17,7	14,1	11,1	8,6	6,5
60	56,0	21,9	56,0	46,8	36,0	28,2	22,4	17,9	14,3	11,4	8,9	-
55	56,0	21,9	56,0	46,9	36,1	28,4	22,6	18,1	14,5	11,6	-	-
50	56,0	21,9	56,0	47,0	36,3	28,7	23,0	18,6	15,0	-	-	-
45	56,0	22,0	56,0	47,4	36,8	29,3	23,6	19,2	-	-	-	-
40	56,0	22,0	56,0	47,5	37,0	29,6	24,0	-	-	-	-	-
35	56,0	22,0	56,0	47,5	37,2	29,8	-	-	-	-	-	-
30	56,0	22,0	56,0	47,6	37,3	-	-	-	-	-	-	-



3R
75 t



	3R @ ...(m)	@ ...(m)	15	20	25	30	35	40	45	50	55
55	65,0	18,9	65,0	60,4	44,7	34,2	26,7	21,0	16,7	13,2	10,3
50	70,0	17,8	70,0	60,4	44,8	34,4	27,0	21,5	17,2	13,7	-
45	75,0	16,8	75,0	60,4	45,1	34,9	27,6	22,2	17,9	-	-
40	75,0	16,8	75,0	60,6	45,4	35,3	28,1	22,7	-	-	-
35	75,0	16,8	75,0	60,7	45,7	35,7	28,5	-	-	-	-
30	75,0	16,8	75,0	60,8	45,9	36,0	-	-	-	-	-

Datos válidos para / Valid data for

Donnees valables pour / Gultige Daten für / Допустимые данные для / البيانات الصالحة لـ



3R H ≤ 105 m
2R H ≤ 110 m
TD H ≤ 115 m

(H) ESTACIONARIA 1 / STATIONARY 1 / STATIONAIRE 1 / STATIONAR 1 / СТАЦИОНАРНОЕ СОСТОЯНИЕ / ثابتة

TD

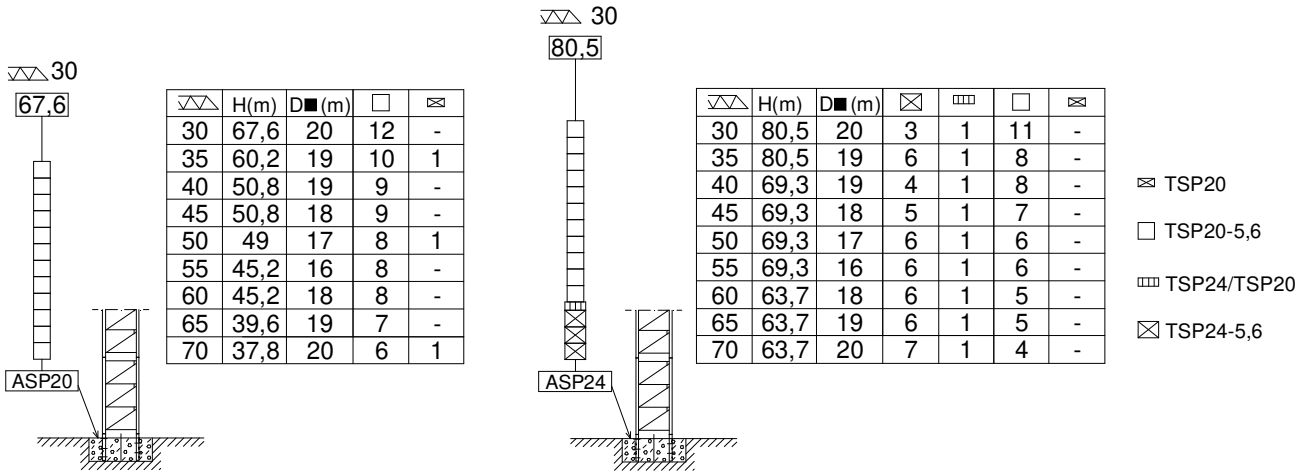

2R

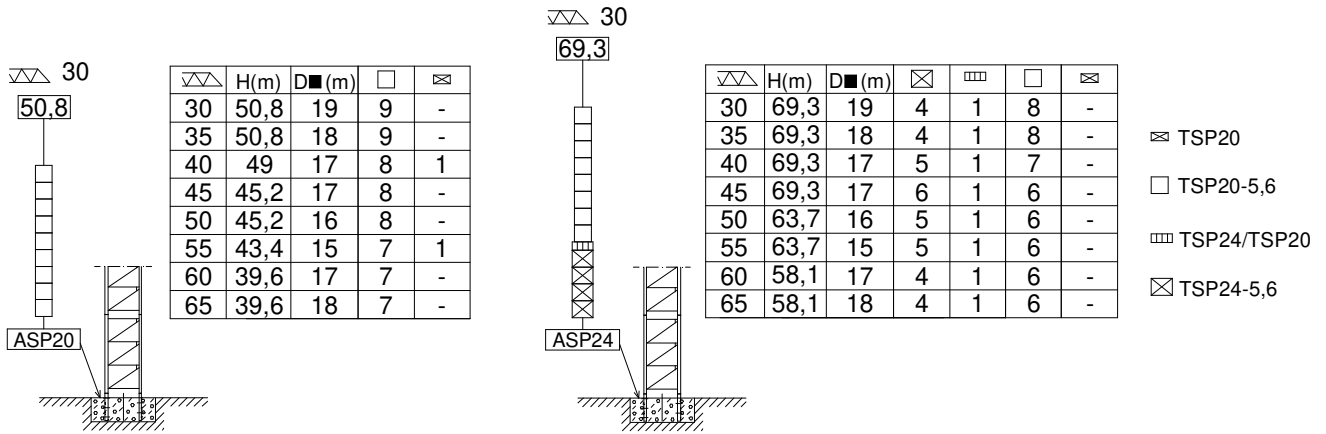

3R

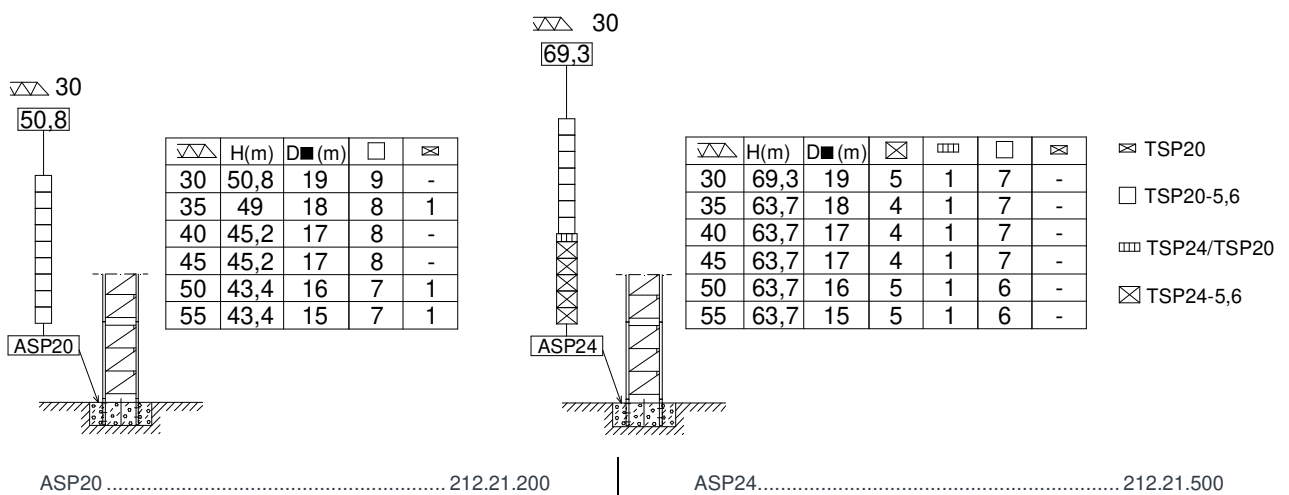

H= Máxima altura de torre sin arriostrar (m) / Maximum tower height without fastening (m) / Hauteur maximale de tour sans ancrage (m) / Maximale Höhe ohne Verstreben (m) / Максимальная высота башни без крепления (м) / أقصى ارتفاع للبرج بدون ربط (م)



Reservado el derecho a modificaciones sin previo aviso. Declinamos toda responsabilidad derivada de la información proporcionada / Subject to modification, without prior notice. This information is supplied without liability. L'entreprise se réserve le droit de procéder à des modifications sans préavis. Nous déclinons toute responsabilité quant aux informations fournies / Das Recht auf Änderungen ohne vorherige Ankündigung bleibt vorbehalten. Wir übernehmen keine Gewähr für die gemachten Angaben / Мы оставляем за собой право на внесение изменений без предварительного уведомления. Мы снимаем с себя любую ответственность отнютии предоставленной информации / حقوق التغيير محفوظة دون إشعار مسبق. دون أننى مسؤولة عن المعلومات المقدمة.



EC300310VF

110 kW

220 kW

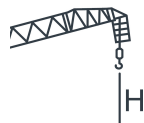
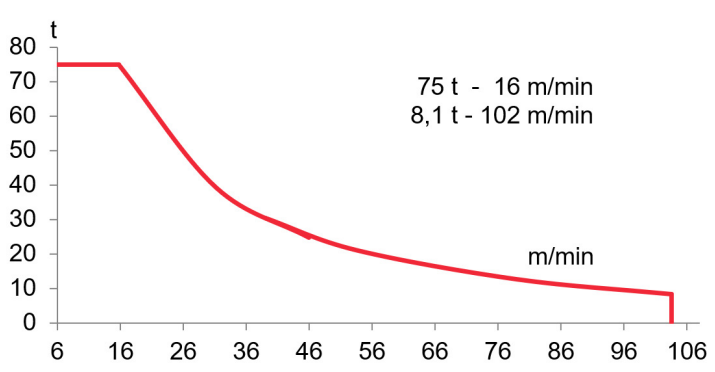
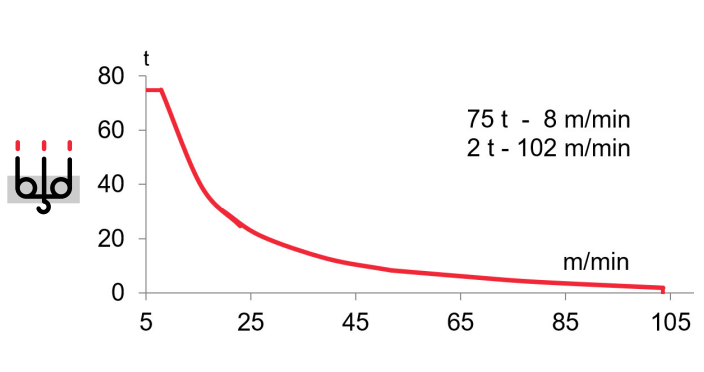
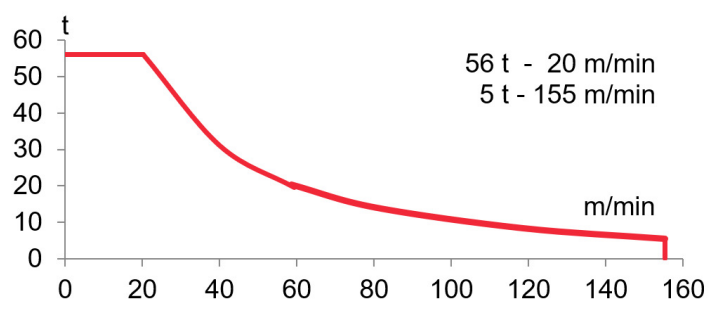
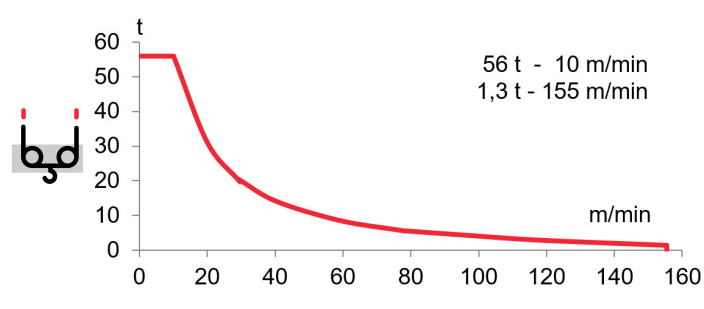
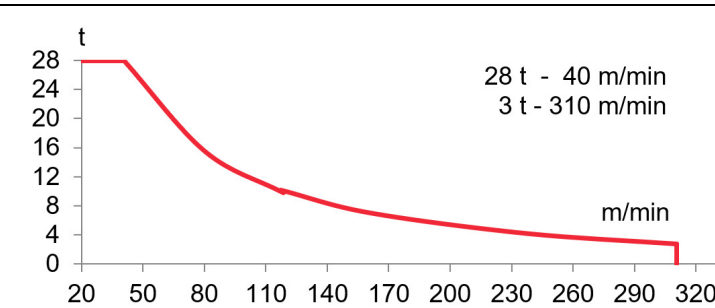
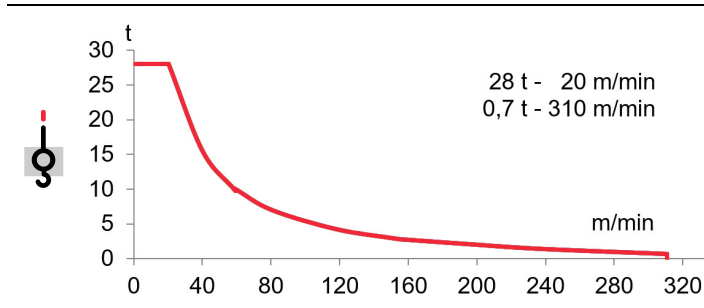

H ≤ TD 1007 m
2R 504 m
3R 336 m

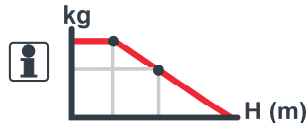
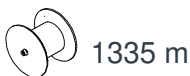

OG4007VF
2 x 15 kW

EP15020VF
110 kW

TH6006
45 kW

0...0,7
r/min
sl/min

1,6... 2,4
min

1,8... 2,8
min

0,6
m/min

⚡ 3~ 400V 50Hz
480V 60Hz

KVA			
EC300310VF - 110kW	195	221	248
EC300310VF - 220kW	266	328	390

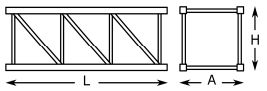
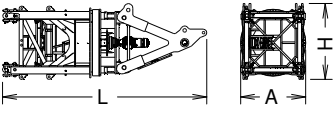
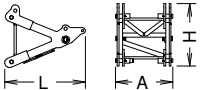
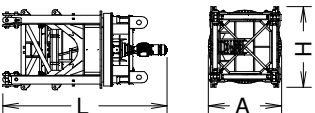
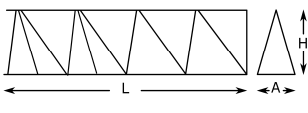
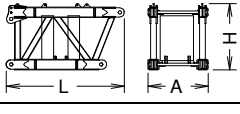
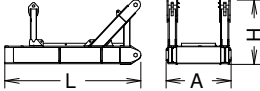
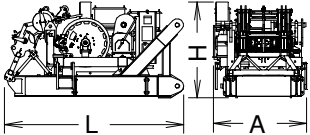
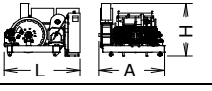
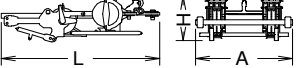
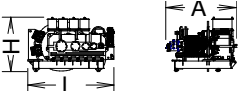
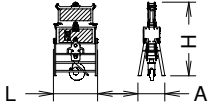
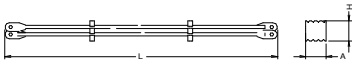
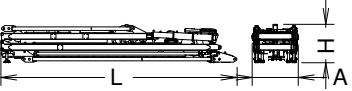

			L (m)	A (m)	H (m)	P/W(kg)
Torre / Tower Tour / Turm / Башня / برج	TSP20 TSP20-5,6 TSP24-5,6		4,374 6,164 6,164	2,285 2,285 2,754	2,383 2,383 2,852	5615 7665 8295
Torre asiento pista, torre superior y orientación Slewing table, top tower and slewing mechanism Tour pivot + tour supérieure + mécanisme d'orientation Turmsitz, + oberer Turm + Ausrichtung Сиденье площадки + верхняя башня + поворотный механизм / برج وحدة الدوران + البرج العلوي + آلية الدوران			7,245	2,315	2,625	25540
Punta de torre / Top tower Tour supérieure / Turmspitze / верхняя башня / رأس البرج			3,200	2,275	2,435	5895
Torre asiento pista + base punta de torre + orientación Slewing table + tower head base + slewing mechanism Tour pivot + base du porte-flèche + mécanisme d'orientation Turmsitz + Turmspitzenbasis + Ausrichtung / Сиденье площадки + основание верхней секции башни + поворотный механизм / برج وحدة الدوران + البرج العلوي + آلية			5,200	2,315	2,545	19645
Tramo de pluma Jib section Tronçon de flèche Auslegerabschnitt Секция стрелы أجزاء الذراع	1 2 3 4 5 6 7 8 9-3R		8,884 10,583 10,583 10,583 10,583 10,583 5,406 5,396 1,997	2,271 2,150 1,988 1,988 1,988 1,988 1,988 1,988 2,032	2,259 2,369 2,277 2,404 2,277 2,258 2,270 2,279 3,610	3940 4315 3710 3320 3290 2880 1815 2305 3030
Contrapluma 1 / Counterjib 1 Contre-flèche 1 / Gegenausleger 1 / Противовесная консоль 1 / الذراع المعاكس 1			4,471	2,290	2,540	9915
Contrapluma 2 / Counterjib 2 Contre-flèche 2 / Gegenausleger 2 / Противовесная консоль 2 / الذراع المعاكس 2			4,793	2,290	2,250	8065
Contrapluma 2 + Elevación pluma + pasteca Counterjib 2 + Luffing mech + Reeving block Contre-flèche 2 + Relevage de flèche + Bloc de renvoi Gegenausleger 2 + Auslegerhebewerk + Unterflasche Противовесная консоль 2 + Подъем стрелы + Канифас-болк / رافع الذراع 2 + المعاكس 2			5,085	2,665	2,725	19250
Elevación pluma / Luffing mech Relevage de flèche / Auslegerhub / Подъем стрелы			2,860	2,480	2,075	8510
Pasteca / Reeving Block Bloc de renvoi / Unterflasche / Канифас-болк			3,340	1,055	2,050	1875
Mecanismo elevacion carga sin cable / Hoisting mechanism without rope Mécánisme de levage de charge sans câble / Lasthubmechanismus ohne Seil Подъем груза / (without rope) / رافع الحمولة (without rope)			3,805	3,110	2,515	20305
Polipasto / Hook assembly Palan / Flaschenzug / Полиспаст / بكرة	TD/2R/3R TD		1,512 0,570	0,950 0,385	2,540 1,745	2030 675
Tirante sostén pluma / Jib support tie Tirant de fleche Haltestange Ausleger Растяжка поддержки стрелы / مشد دعامة الذراع			5,416 5,416	0,360 0,360	0,400 0,400	1390 1375
Parte superior + mecanismo auxiliar Top part + auxiliary winch Partie supérieure + mécanisme auxiliaire Oberteil + zusätzlicher Mechanismus			11,825	2,300	1,978	17800

LISTA DE EMBARQUE / PACKING LIST

LISTE DE COLISAGE / KOLLI LISTE / СПИСОК ПОСТАВКИ / قائمة التحميل

J780PA

		L (m)	A (m)	H (m)	P/W(kg)
Plataforma y cabina / Platform and cabin Plateforme et cabine / Plattform + Führerstand Платформа и кабина / منصة وكابينة		3,670	2,300	2,480	1250
Contrapeso / Counterweight Contrepoids / Gegengewichte / Противовес / اوزان معاكسة		4,500	0,235	1,005	8000
Transporte torre de montaje Jacking cage transport Transport de tour de montage Transport Montageturm Транспортировка монтажной башни نقل برج التركيب	TM20PASP-5,6 - Package 1 	11,610	2,220	2,485	11915
	TM20PASP-5,6 - Package 2 	11,670	2,010	2,485	14430

TREPADO / CLIMBING / TÉLESCOPAGE / KLETTERSYSTEM / ЛЕСТНИЦА / التسلق

J780PA

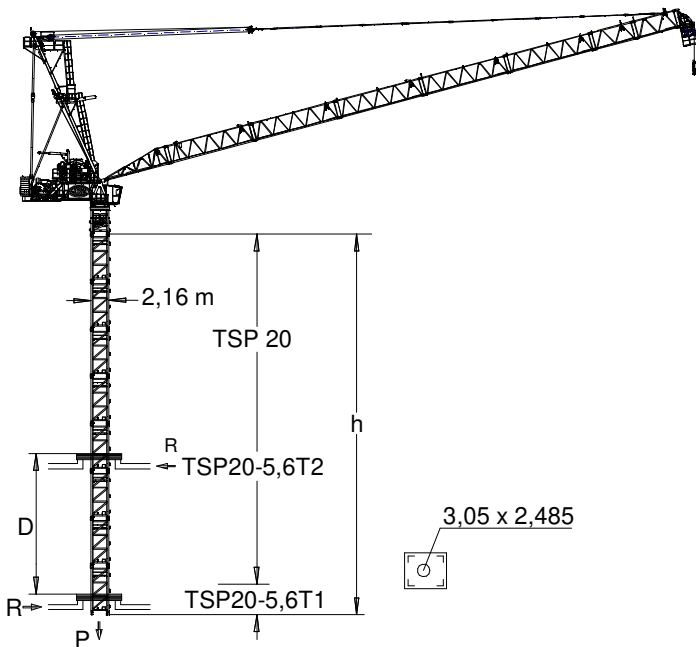

TSP20-5,6T1: 214.31.400

TSP20-5,6T2: 214.31.600

h_{max} :
TSP20-5,6T1 + 4 x TSP20-5,6 + TSP20-5,6T2 + TSP20

70 m → H		
h (m)	37,4	
D (m)	13,4 – 17,2	
P (KN)	3095	2815
Rmax (KN)	885	1135

h_{max} :
TSP20-5,6T1 + 5 x TSP20-5,6 + TSP20-5,6T2

60 m → H		
h (m)	39,2	
D (m)	13,4 – 18,1	
P (KN)	3330	2765
Rmax (KN)	895	1185

h_{max} :
TSP20-5,6T1 + 6 x TSP20-5,6 + TSP20-5,6T2

45 m → H		
h (m)	44,8	
D (m)	12,6 – 20,9	
P (KN)	3500	2750
Rmax (KN)	940	1300

Trepado interno / Internal climbing / Téléscoage / Inneres klettersystem / Внутренняя лестница / التسلق الداخلي

Viento fuera de servicio / Out of service wind / Vitesse du vent hors service / Wind außer betrieb / Ветровая нагрузка в покое / الريح خارج الخدمة

Consultar / Consult / Nous consulter / Anfragen / Консультируйтесь / الرجوع إلى

En servicio / In service / En service / In betrieb / В работе / في الخدمة

Fuera de servicio / Out of service / Hors service / Außer betrieb / В покое / خارج الخدمة

Opcional / Optional / En option / Optional / Опция / اختياري



Ctra./ Rd. Madrid – Irún - Km. 415 - 20213 IDIAZABAL (Gipuzkoa) - ESPAÑA / SPAIN

P.O. Box, 23 - 20.200 - BEASAIN - E-mail: jaso@jaso.com

Tel. +34 943 - 18 70 00 • Fax. +34 943 - 18 70 20

www.jaso.com

29/11/2024

FEM 1001

DELEGACIÓN / DEALER

Reservado el derecho a modificaciones sin previo aviso. Declinamos toda responsabilidad derivada de la información proporcionada / Subject to modification, without prior notice. This information is supplied without liability / L'entreprise se réserve le droit de procéder à des modifications sans préavis. Nous déclinons toute responsabilité quant aux informations fournies / Das Recht auf Änderungen ohne vorherige Ankündigung bleibt vorbehalten. Wir übernehmen keine Gewähr für die gemachten Angaben / Мы оставляем за собой право на внесение изменений без предварительного уведомления. Мы снимаем с себя любую ответственность в отношении предоставленной информации / حقوق التغيير محفوظة دون إشعار مسبق. دون أدنى مسؤولية عن المعلومات المقدمة