



J780PA.64

UNE 58-101
FEM1001

GRUA TORRE / TOWER CRANE

FEM 1001

UNE-EN-ISO 9001

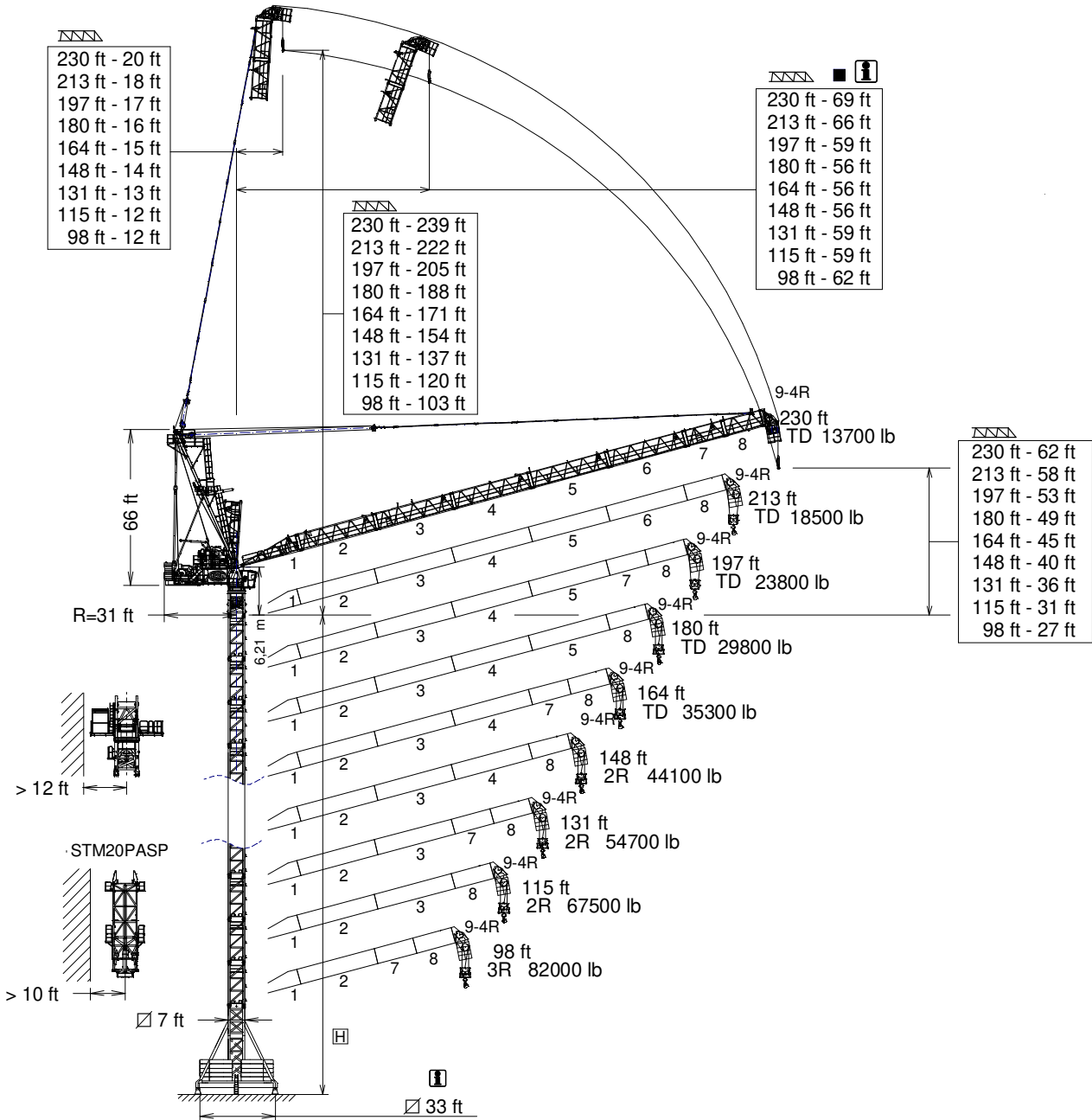

D ■ Distancias fuera de servicio dependen de la altura de la torre / Out of service distances depend on tower height

H= Máxima altura de torre sin arriostrar (ft) / Maximum tower height without fastening (ft)

* Tramo pluma / Jib section

*Tramo pluma 1 / Jib setion 1	800.40.450
*Tramo pluma 2 / Jib setion 2	800.41.700
*Tramo pluma 3 / Jib setion 3	800.42.700
*Tramo pluma 4 / Jib setion 4	800.43.800
*Tramo pluma 5 / Jib setion 5	800.44.600

*Tramo pluma 6 / Jib setion 6	800.45.700
*Tramo pluma 7 / Jib setion 7	800.46.800
*Tramo pluma 8 / Jib setion 8	214.47.000
*Tramo pluma 9-4R / Jib setion 9-4R	801.48.000

TSP20	214.31.300
TSP20-5,6	214.31.100
TSP24-5,6	214.32.200
TSP24/TSP20	212.36.000

CUSTOMIZE YOUR CRANE

OPTIMUS
line JASD



OPTI Cube



TC Diagnosis SYSTEM



CLIMBING Solution



SAFETY Pack



Customization



ECO Mode



COMFORT Cabin



HIGH POWER Motors



JL25 Tower Crane Elevator



BE SMART keep control



Reservado el derecho a modificaciones sin previo aviso. Declinamos toda responsabilidad derivada de la información proporcionada / Subject to modification, without prior notice. This information is supplied without liability

25/04/2025



	TD @ ...(ft)	82	98	115	131	148	164	180	197	213	230
	TD @ ...(ft)	82	98	115	131	148	164	180	197	213	230
230	167	35300	35300	35300	35300	35300	35300	29500	23400	18100	13700
213	167	35300	35300	35300	35300	35300	35300	29500	23600	18500	-
197	168	35300	35300	35300	35300	35300	35300	29800	23800	-	-
180	168	35300	35300	35300	35300	35300	35300	29800	-	-	-
164	164	35300	35300	35300	35300	35300	35300	-	-	-	-
148	148	35300	35300	35300	35300	35300	-	-	-	-	-
131	131	35300	35300	35300	35300	-	-	-	-	-	-
115	115	35300	35300	35300	-	-	-	-	-	-	-
98	98	35300	35300	-	-	-	-	-	-	-	-



	2R max (lb)	@ ...(ft)	82	98	115	131	148	164	180	197	213	230
	2R max (lb)	@ ...(ft)	82	98	115	131	148	164	180	197	213	230
230	61700	119	61700	61700	61700	52000	41400	33100	26000	20300	15400	11200
213	70500	110	70500	70500	65500	52000	41700	33300	26500	20900	16100	-
197	70500	110	70500	70500	65500	52200	41900	33700	26900	21400	-	-
180	70500	110	70500	70500	65500	52500	42100	34000	27300	-	-	-
164	70500	110	70500	70500	66100	53100	43000	34800	-	-	-	-
148	70500	111	70500	70500	67200	54200	44100	-	-	-	-	-
131	70500	112	70500	70500	67500	54700	-	-	-	-	-	-
115	70500	112	70500	70500	67500	-	-	-	-	-	-	-
98	70500	98	70500	70500	-	-	-	-	-	-	-	-



	3R max (lb)	@ ...(ft)	66	82	98	115	131	148	164	180	197	213
	3R max (lb)	@ ...(ft)	66	82	98	115	131	148	164	180	197	213
213	92600	89	92600	92600	79400	62200	49200	39000	30900	24300	18700	14100
197	105800	81	105800	103400	79400	62400	49400	39500	31300	24900	19400	-
180	105800	81	105800	103400	79600	62600	49800	39900	32000	25400	-	-
164	105800	81	105800	104100	80200	63300	50700	40800	32800	-	-	-
148	105800	81	105800	104700	81100	64400	51800	42100	-	-	-	-
131	105800	81	105800	104700	81600	65000	52700	-	-	-	-	-
115	105800	81	105800	104700	81800	65500	-	-	-	-	-	-
98	105800	81	105800	104700	82000	-	-	-	-	-	-	-



	4R @ ...(ft)	49	66	82	98	115	131	148	164	180
	4R @ ...(ft)	49	66	82	98	115	131	148	164	180
180	64	141100	136700	101400	78000	61300	48700	38800	31100	24700
164	64	141100	136700	101900	78700	61900	49600	39900	32200	-
148	64	141100	137600	103000	79800	63500	51100	41400	-	-
131	64	141100	137600	103400	80500	64200	52000	-	-	-
115	64	141100	137600	103600	80900	64800	-	-	-	-
98	64	141100	137600	103800	81400	-	-	-	-	-

Datos válidos para / Valid data for



- 4R H ≤ 328 ft
- 3R H ≤ 344 ft
- 2R H ≤ 361 ft
- TD H ≤ 377 ft

(H) ESTACIONARIA 1 / STATIONARY 1

TD

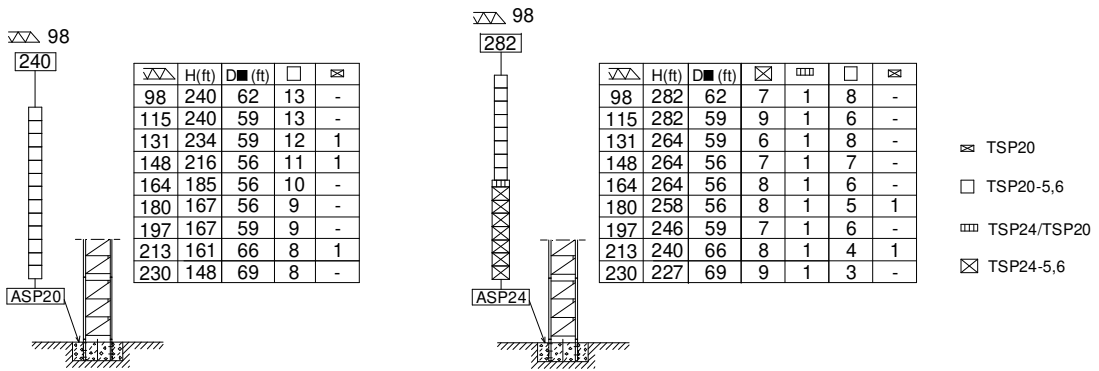

2R

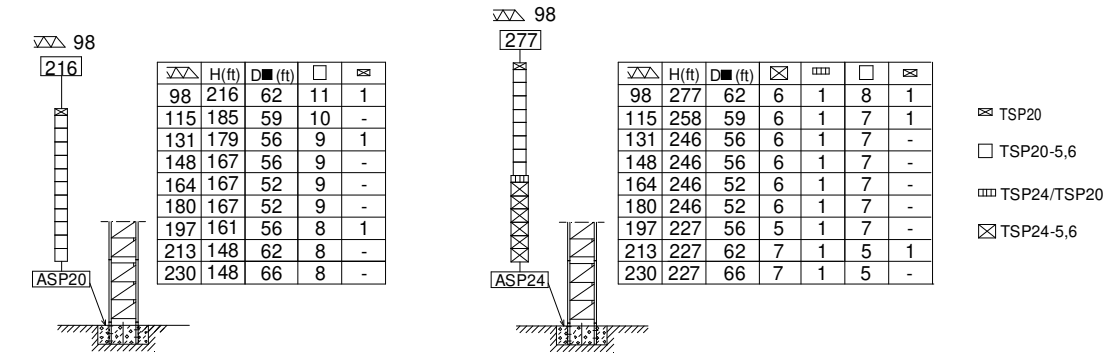

3R

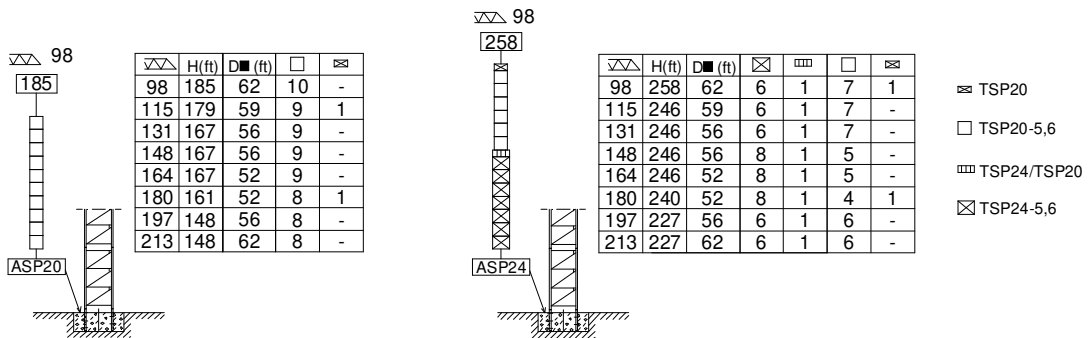

4R

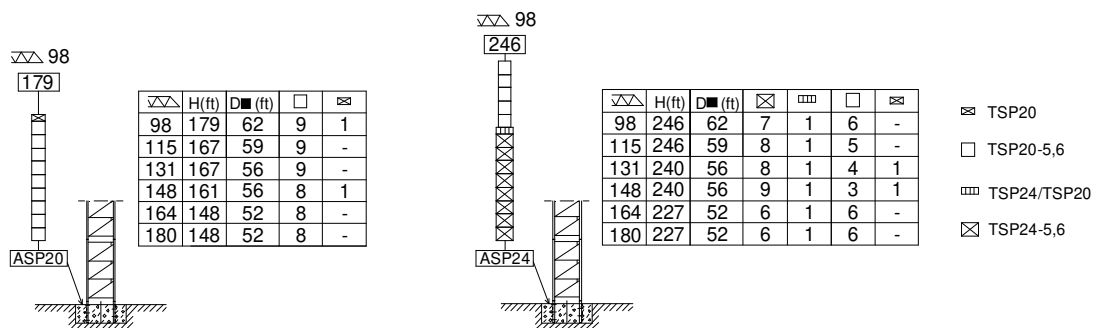

ASP20 212.21.200

ASP24..... 212.21.500

H= Máxima altura de torre sin arriostrar (ft) / Maximum tower height without fastening (ft)





EC150160VF
110 kW

*** EC180200VF**
132 kW

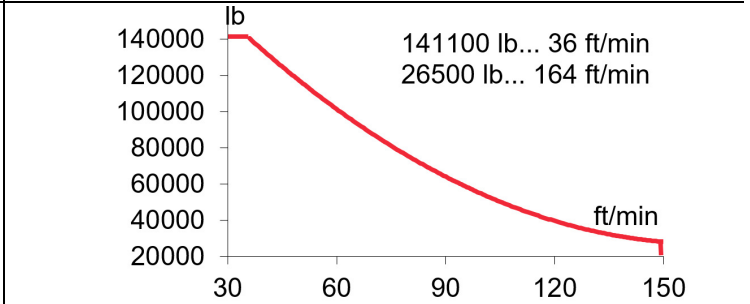
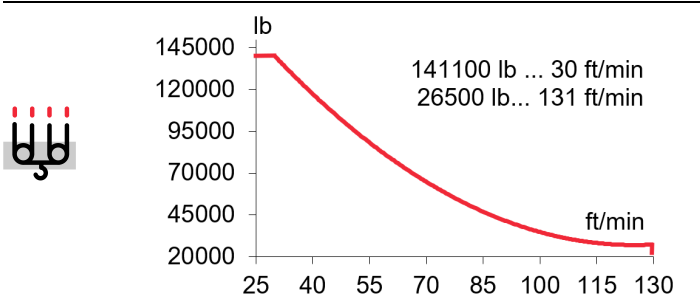
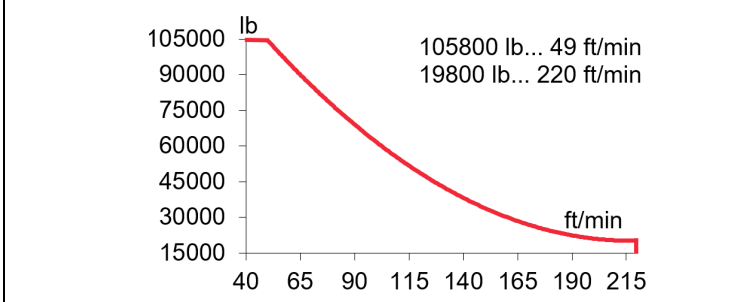
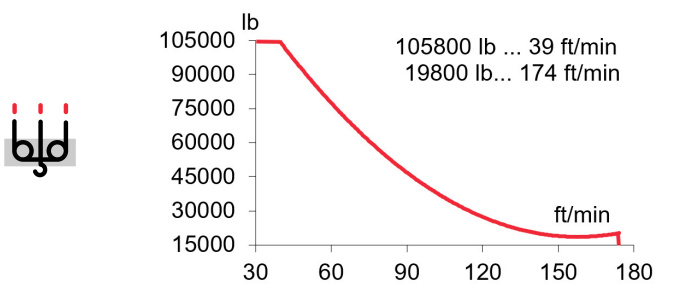
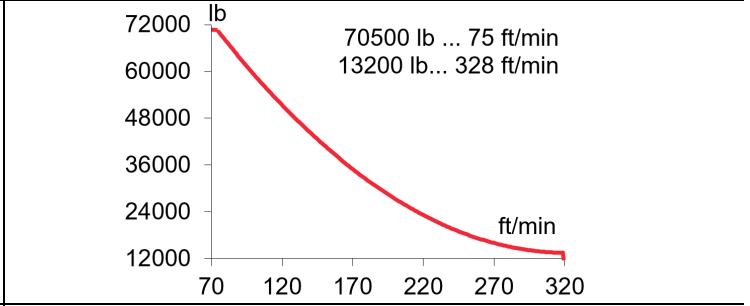
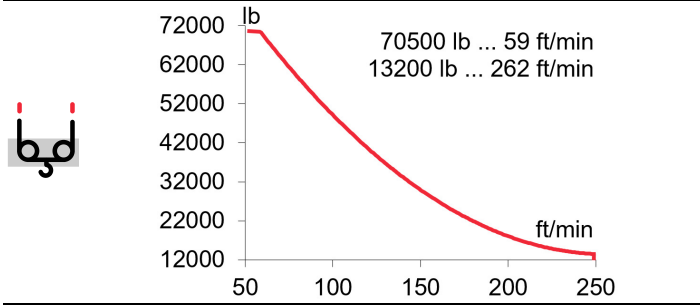
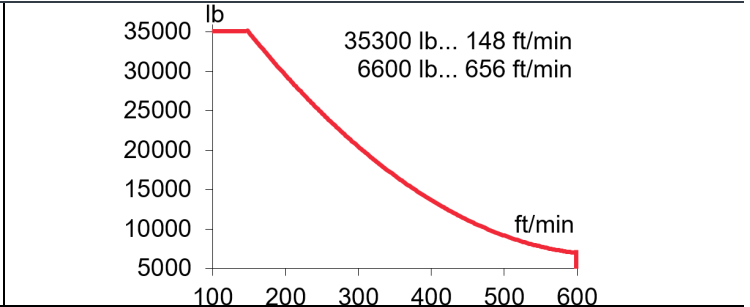
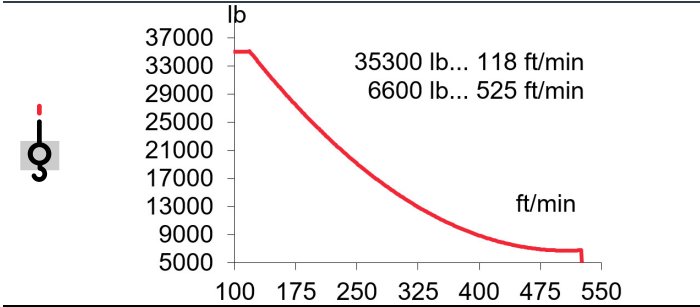

T	2992 ft
2R	1496 ft
3R	997 ft
4R	748 ft

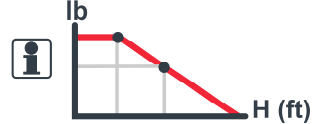

OG4007VF
2 x 15 kW

0...0,7
r/min
sl/min



EP15020VF
110 kW

2
min

⚡ 3~ 400V 50Hz
480V 60Hz

KVA			
EC150160VF	195	221	248
EC180200VF	205	237	269

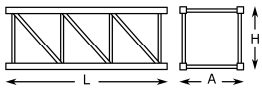
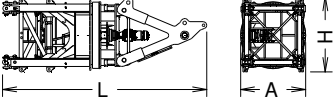
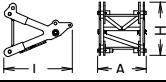
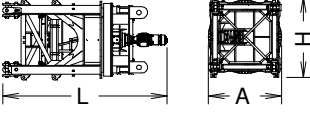
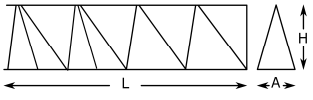
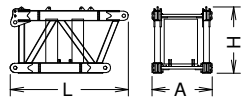
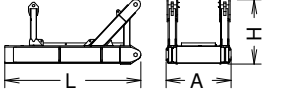
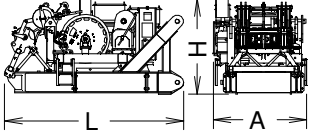
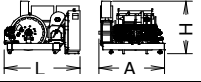
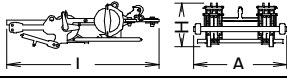
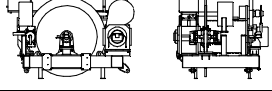
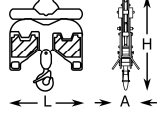
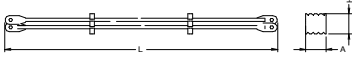
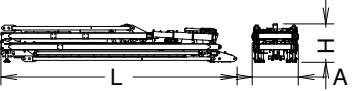
		L (ft)	A (dt)	H (ft)	P/W(lb)	
Torre / Tower	TSP20 TSP20-5,6		14.4	7.5	7.8	12380
			20.2	7.5	7.8	16900
Torre asiento pista, torre superior y orientación Slewing table, top tower and slewing mechanism			23.8	7.6	8.6	56310
Punta de torre / Top tower			10.5	7.5	8.0	13000
Torre asiento pista + base punta de torre + orientación Slewing table + tower head base + slewing mechanism			17.1	7.6	8.3	43310
Tramo de pluma Jib section	1		29.1	7.5	7.4	8690
	2		34.7	7.1	7.8	9510
	3		34.7	6.5	7.5	8180
	4		34.7	6.5	7.9	7320
	5		34.7	6.5	7.5	7255
	6		34.7	6.5	7.4	6350
	7		17.7	6.5	7.4	4000
	8		17.7	6.5	7.5	5080
	9-4R		6.6	6.7	11.8	6680
Contrapluma 1 / Counterjib 1			14.7	7.5	8.3	21860
Contrapluma 2 / Counterjib 2			15.7	7.5	7.4	17780
Contrapluma 2 + Elevación pluma + pasteca Counterjib 2 + Luffing mech + Reeving block			16.7	8.7	8.9	42440
Elevación pluma / Luffing mech			9.4	8.1	6.8	16470
Pasteca / Reeving Block			11.0	3.5	6.7	4130
Mecanismo elevacion carga sin cable / Hoisting mechanism without rope			10.5	7.7	6.5	16530
Polipasto / Hook assembly	4R 2R/3R TD		4.5	1.7	8.5	3730
			5.0	3.1	8.3	3680
			0.6	1.1	6.9	840
Tirante sostén pluma / Jib support tie			17.8	1.2	1.3	3060
			17.8	1.2	1.3	3030
Parte superior + mecanismo auxiliar Top part + auxiliary winch			38.8	7.5	6.5	39240

LISTA DE EMBARQUE / PACKING LIST

J780PA.64

		L (ft)	A (dt)	H (ft)	P/W(lb)
Plataforma y cabina / Platform and cabin		12.0	7.5	8.1	2760
Contrapeso / Counterweight		14.8 7.6	0.8 0.8	3.3 3.3	17640 8820
Transporte torre de montaje Jacking cage transport	TM20PASP-5,6 - Package 1. 	38.1	7.3	8.2	26270
	TM20PASP-5,6 - Package 2 	38.3	6.6	8.2	31810

TREPADO / CLIMBING

J780PA.64

$h_{max}: TSP20-5,6T1 + 6 \times TSP20-5,6 + TSP20-5,6T2$

	▶	■
230 ft → H		
h (ft)	147	
D (ft)	43 - 69	
P (lbf)	674430	611480
Rmax (lbf)	204580	296750

$h_{max}: TSP20-5,6T1 + 6 \times TSP20-5,6 + TSP20-5,6T2$

	▶	■
213 ft → H		
h (ft)	147	
D (ft)	43 - 69	
P (lbf)	698030	626090
Rmax (lbf)	203450	300120

$h_{max}: TSP20-5,6T1 + 6 \times TSP20-5,6 + TSP20-5,6T2$

	▶	■
197 ft → H		
h (ft)	147	
D (ft)	44 - 69	
P (lbf)	731750	623840
Rmax (lbf)	201200	291130

$h_{max}: TSP20-5,6T1 + 6 \times TSP20-5,6 + TSP20-5,6T2$

	▶	■
180 ft → H		
h (ft)	147	
D (ft)	46 - 69	
P (lbf)	754230	610360
Rmax (lbf)	196710	275390

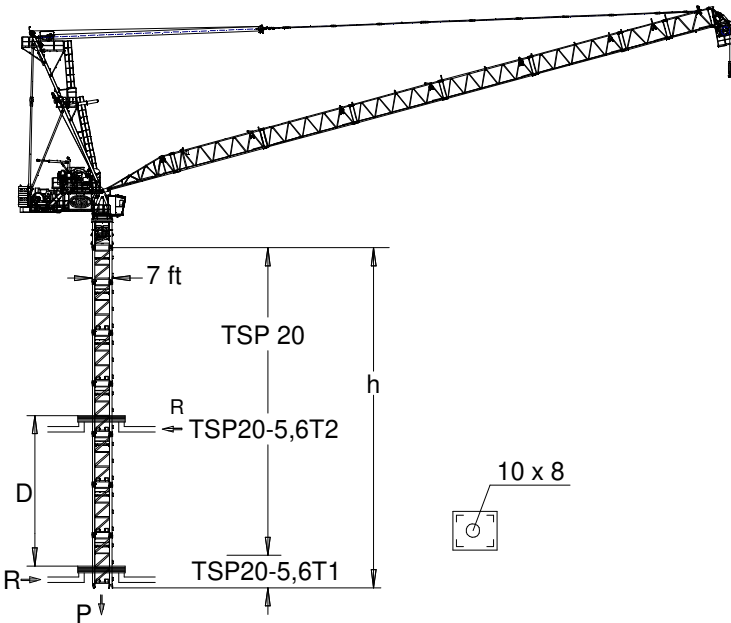

TSP20-5,6T1: 214.31.400
TSP20-5,6T2: 214.31.600

- ▶ Trepado interno / Internal climbing
- ▶ Viento fuera de servicio / Out of service wind
- ▶ Consultar / Consult
- ▶ En servicio / In service
- Fuera de servicio / Out of service
- * Opcional / Optional



Ctra./ Rd. Madrid – Irún - Km. 415 - 20213 IDIAZABAL (Gipuzkoa) - ESPAÑA / SPAIN
P.O. Box, 23 - 20.200 - BEASAIN - E-mail: jaso@jaso.com
Tel. +34 943 - 18 70 00 • Fax. +34 943 - 18 70 20
www.jaso.com

25/04/2025



DELEGACIÓN / DEALER