



# J780PA.64

EN 14439  
C25

**GRUA TORRE / TOWER CRANE**  
GRUE A TOUR / TURMDREHKRAN / БАШЕННЫЙ КРАН / رافعة برجية

FEM 1005 - C25

UNE-EN-ISO 9001

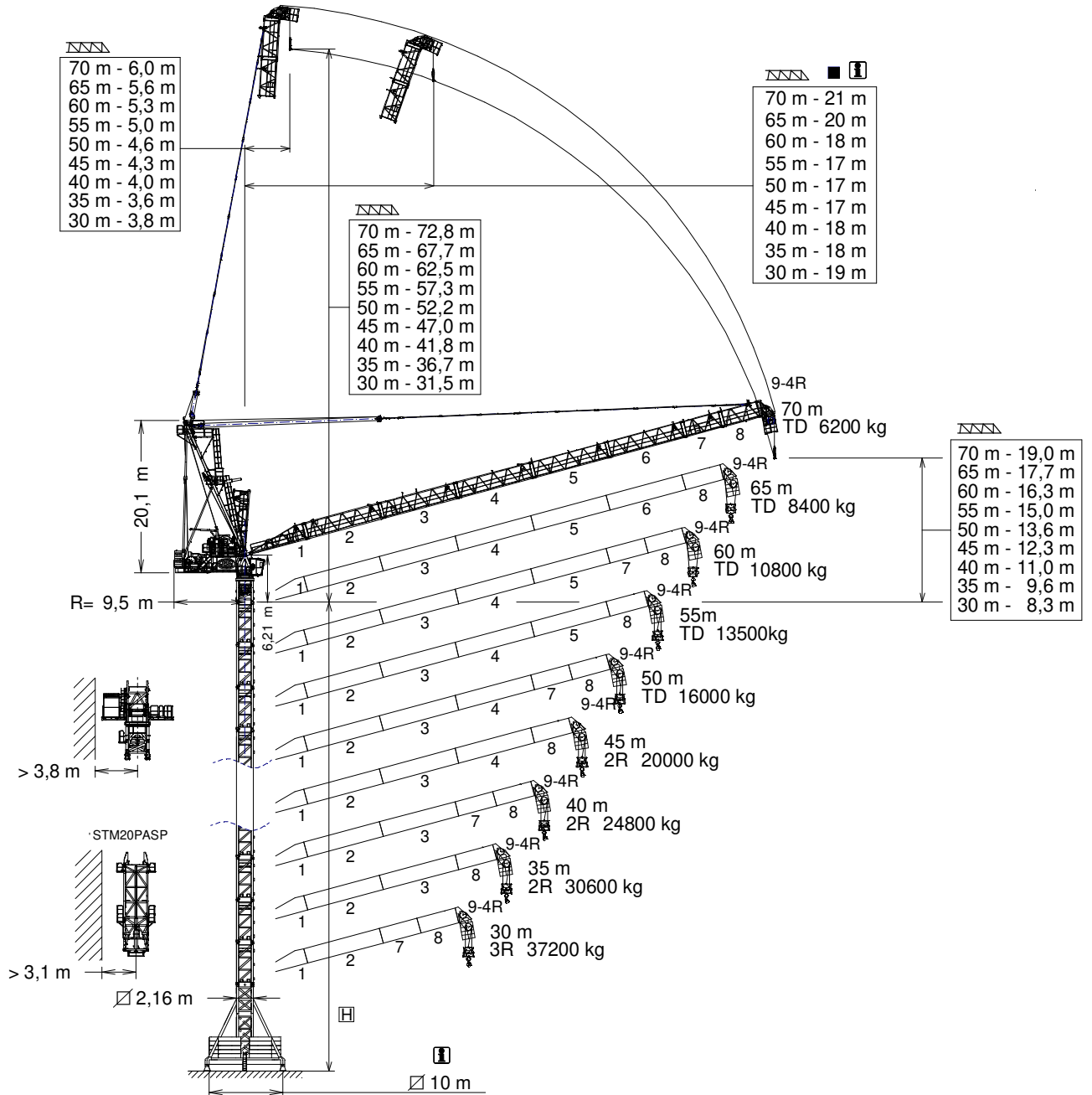

D ■ Distancias fuera de servicio dependen de la altura de la torre / Out of service distances depend on tower height / Distances hors service dépendent de la hauteur de la tour / Die Außerbetriebnahmereichweiten hängen von der Höhe des Turms ab

H= Máxima altura de torre sin arriostrar (m) / Maximum tower height without fastening (m)

Hauteur maximale de tour sans ancrage (m) / Maximale Höhe ohne Verstreben (m) / Максимальная высота башни без крепления (м) / أقصى ارتفاع للبرج بدون ربط (م) / أجزاء التراع

*Tramo pluma 1 / Jib setion 1	800.40.450
*Tramo pluma 2 / Jib setion 2	800.41.700
*Tramo pluma 3 / Jib setion 3	800.42.700
*Tramo pluma 4 / Jib setion 4	800.43.800
*Tramo pluma 5 / Jib setion 5	800.44.600

*Tramo pluma 6 / Jib setion 6	800.45.700
*Tramo pluma 7 / Jib setion 7	800.46.800
*Tramo pluma 8 / Jib setion 8	214.47.000
*Tramo pluma 9-4R / Jib setion 9-4R	801.48.000

TSP20	214.31.300
TSP20-5.6	214.31.100
TSP24-5.6	214.32.200
TSP24/TSP20	212.36.000

## CUSTOMIZE YOUR CRANE

**OPTIMUS**  
line JASD



OPTI Cube



TC Diagnosis SYSTEM



CLIMBING Solution



SAFETY Pack



Customization



ECO Mode



COMFORT Cabin



HIGH POWER Motors



JL25 Tower Crane Elevator









BE SMART keep control



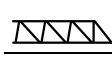





Reservado el derecho a modificaciones sin previo aviso. Declinamos toda responsabilidad derivada de la información proporcionada / Subject to modification, without prior notice. This information is supplied without liability / L'entreprise se réserve le droit de procéder à des modifications sans préavis. Nous déclinons toute responsabilité quant aux informations fournies / Das Recht auf Änderungen ohne vorherige Ankündigung bleibt vorbehalten. Wir übernehmen keine Gewähr für die gemachten Angaben / Мы оставляем за собой право на внесение изменений без предварительного уведомления. Мы снимаем с себя любую ответственность в отношении предоставленной информации / حقوق التغيير محفوظة دون إشعار مسبق دون أدنى مسؤولية عن المعلومات المقدمة

29/11/2024

 <b>TD</b> <b>16 t</b>												
	<b>TD</b> @ ... (m)	25	30	35	40	45	50	55	60	65	70	
70	51,0	16,0	16,0	16,0	16,0	16,0	16,0	13,4	10,6	8,2	6,2	
65	51,0	16,0	16,0	16,0	16,0	16,0	16,0	13,4	10,7	8,4	-	
60	51,1	16,0	16,0	16,0	16,0	16,0	16,0	13,5	10,8	-	-	
55	51,1	16,0	16,0	16,0	16,0	16,0	16,0	13,5	-	-	-	
50	50,0	16,0	16,0	16,0	16,0	16,0	16,0	-	-	-	-	
45	45,0	16,0	16,0	16,0	16,0	16,0	-	-	-	-	-	
40	40,0	16,0	16,0	16,0	16,0	-	-	-	-	-	-	
35	35,0	16,0	16,0	16,0	-	-	-	-	-	-	-	
30	30,0	16,0	16,0	-	-	-	-	-	-	-	-	

 <b>2R</b> <b>32 t</b>												
	<b>2R</b> @ ... (m)	<b>2R</b> @ ... (m)	25	30	35	40	45	50	55	60	65	70
70	28,0	36,3	28,0	28,0	28,0	23,6	18,8	15,0	11,8	9,2	7,0	5,1
65	32,0	33,4	32,0	32,0	29,7	23,6	18,9	15,1	12,0	9,5	7,3	-
60	32,0	33,4	32,0	32,0	29,7	23,7	19,0	15,3	12,2	9,7	-	-
55	32,0	33,4	32,0	32,0	29,7	23,8	19,1	15,4	12,4	-	-	-
50	32,0	33,6	32,0	32,0	30,0	24,1	19,5	15,8	-	-	-	-
45	32,0	33,9	32,0	32,0	30,5	24,6	20,0	-	-	-	-	-
40	32,0	34,0	32,0	32,0	30,6	24,8	-	-	-	-	-	-
35	32,0	34,0	32,0	32,0	30,6	-	-	-	-	-	-	-
30	32,0	30,0	32,0	32,0	-	-	-	-	-	-	-	-

 <b>3R</b> <b>48 t</b>												
	<b>3R</b> @ ... (m)	<b>3R</b> @ ... (m)	20	25	30	35	40	45	50	55	60	65
65	42,0	27,1	42,0	42,0	36,0	28,2	22,3	17,7	14,0	11,0	8,5	6,4
60	48,0	24,6	48,0	46,9	36,0	28,3	22,4	17,9	14,2	11,3	8,8	-
55	48,0	24,6	48,0	46,9	36,1	28,4	22,6	18,1	14,5	11,5	-	-
50	48,0	24,7	48,0	47,2	36,4	28,7	23,0	18,5	14,9	-	-	-
45	48,0	24,8	48,0	47,5	36,8	29,2	23,5	19,1	-	-	-	-
40	48,0	24,8	48,0	47,5	37,0	29,5	23,9	-	-	-	-	-
35	48,0	24,8	48,0	47,5	37,1	29,7	-	-	-	-	-	-
30	48,0	24,8	48,0	47,5	37,2	-	-	-	-	-	-	-

 <b>4R</b> <b>64 t</b>										
	<b>4R</b> @ ... (m)	15	20	25	30	35	40	45	50	55
55	19,5	64,0	62,0	46,0	35,4	27,8	22,1	17,6	14,1	11,2
50	19,5	64,0	62,0	46,2	35,7	28,1	22,5	18,1	14,6	-
45	19,6	64,0	62,4	46,7	36,2	28,8	23,2	18,8	-	-
40	19,6	64,0	62,4	46,9	36,5	29,1	23,6	-	-	-
35	19,6	64,0	62,4	47,0	36,7	29,4	-	-	-	-
30	19,6	64,0	62,4	47,1	36,9	-	-	-	-	-

Datos válidos para / Valid data for  
Donnees valables pour / Gültige Daten für / Допустимые данные для / البيانات الصالحة لـ

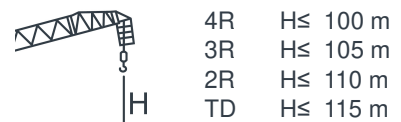

(H) ESTACIONARIA 1 / STATIONARY 1 / STATIONAIRE 1 / STATIONÄR 1 / СТАЦИОНАРНОЕ СОСТОЯНИЕ / ثابتة

TD

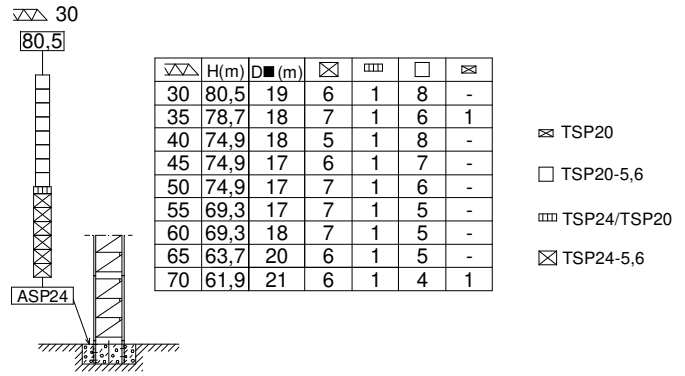
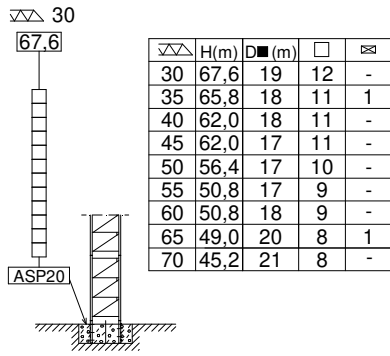

- ⊠ TSP20
- TSP20-5,6
- ⊠ TSP24/TSP20
- ⊠ TSP24-5,6

2R

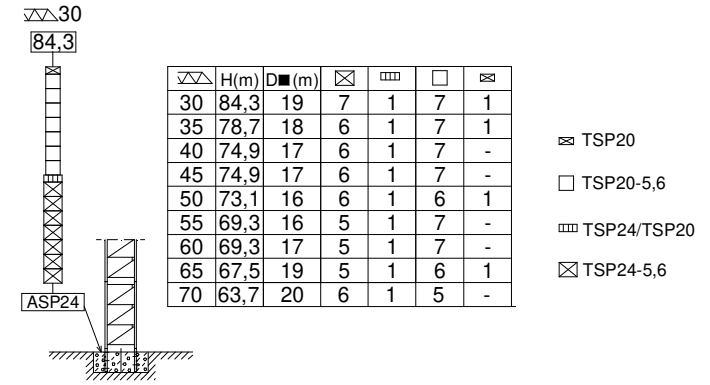
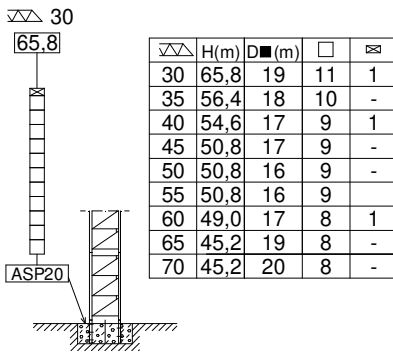

- ⊠ TSP20
- TSP20-5,6
- ⊠ TSP24/TSP20
- ⊠ TSP24-5,6

3R

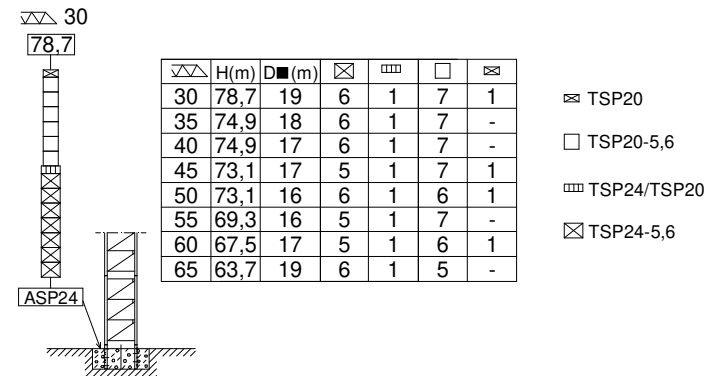
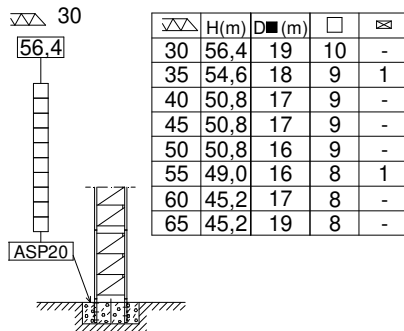

- ⊠ TSP20
- TSP20-5,6
- ⊠ TSP24/TSP20
- ⊠ TSP24-5,6

4R

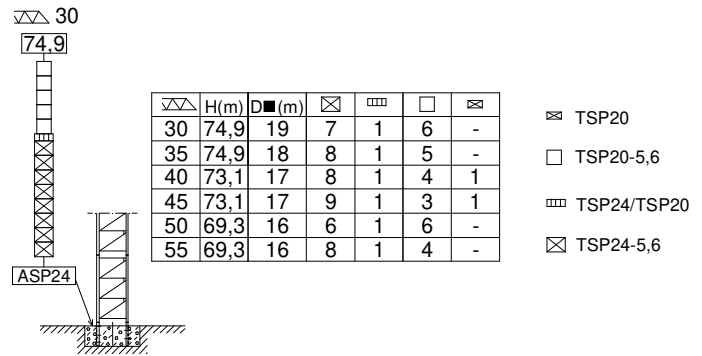
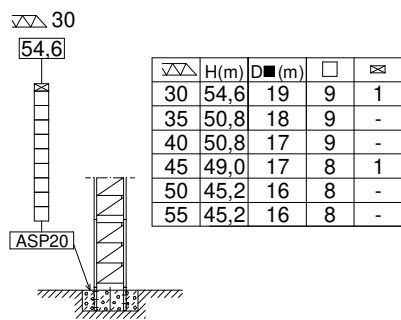

- ⊠ TSP20
- TSP20-5,6
- ⊠ TSP24/TSP20
- ⊠ TSP24-5,6

ASP20 .....212.21.200

ASP24 .....212.21.500

H= Máxima altura de torre sin arriostrar (m) / Maximum tower height without fastening (m) / Hauteur maximale de tour sans ancrage (m) / Maximale Höhe ohne Verstrecken (m) / Максимальная высота башни без крепления (m) / أقصى ارتفاع للبرج بدون ربط (م)



Reservado el derecho a modificaciones sin previo aviso. Declinamos toda responsabilidad derivada de la información proporcionada / Subject to modification, without prior notice. This information is supplied without liability. L'entreprise se réserve le droit de procéder à des modifications sans préavis. Nous déclinons toute responsabilité quant aux informations fournies / Das Recht auf Änderungen ohne vorherige Ankündigung bleibt vorbehalten. Wir übernehmen keine Gewähr für die gemachten Angaben / Мы оставляем за собой право на внесение изменений без предварительного уведомления. Мы снимаем с себя любую ответственность отнютии предоставленной информации / حقوق التغيير محفوظة دون إشعار مسبق. دون اننى مسؤولة عن المعلومات المقدمة.



**EC150160VF**  
110 kW

**\* EC180200VF**  
132 kW

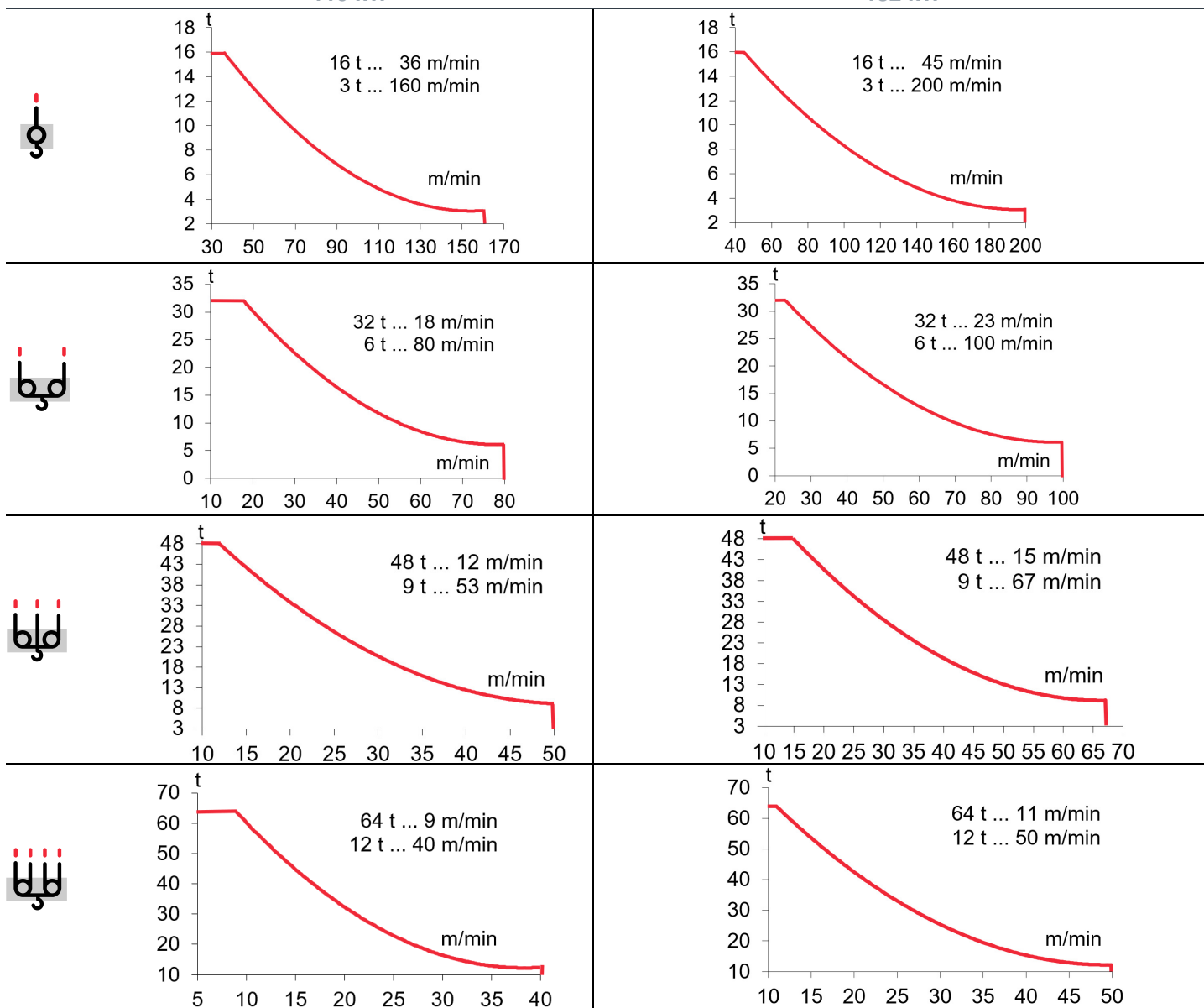

T	912 m
2R	456 m
3R	304 m
4R	228 m

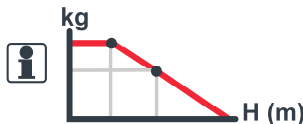

**OG4007VF**  
2 x 15 kW

0...0,7  
r/min  
sl/min



**EP15020VF**  
110 kW

2  
min

⚡ 3~ 400V 50Hz  
480V 60Hz

KVA			
EC150160VF	195	221	248
EC180200VF	205	237	269

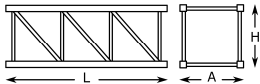
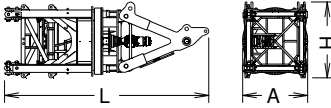
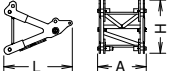
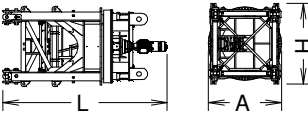
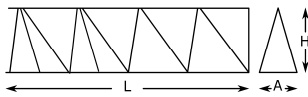
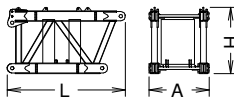
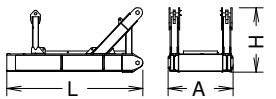
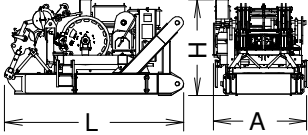
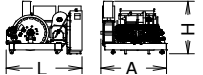
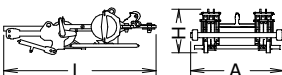
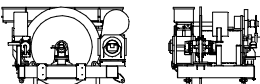
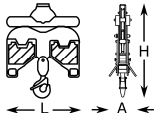
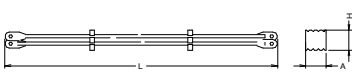
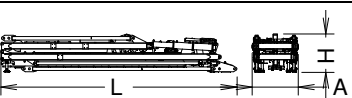
		L (m)	A (m)	H (m)	P/W(kg)	
<b>Torre / Tower</b> Tour / Turm / Башня / برج	TSP20 TSP20-5,6		4,374 6,164	2,285 2,285	2,383 2,383	5615 7665
<b>Torre asiento pista, torre superior y orientación</b> <b>Slewing table, top tower and slewing mechanism</b> Tour pivot + tour supérieure + mécanisme d'orientation Turmsitz, + oberer Turm + Ausrichtung Сиденье площадки + верхняя башня + поворотный механизм / برج وحدة الدوران + البرج العلوي + آلية الدوران			7,245	2,315	2,625	25540
<b>Punta de torre / Top tower</b> Tour supérieure / Turmspitze / верхняя башня / رأس البرج			3,200	2,275	2,435	5895
<b>Torre asiento pista + base punta de torre + orientación</b> <b>Slewing table + tower head base + slewing mechanism</b> Tour pivot + base du porte-flèche + mécanisme d'orientation Turmsitz + Turmspitzenbasis + Ausrichtung / Сиденье площадки + основание верхней секции башни + поворотный механизм / برج وحدة الدوران + البرج العلوي + آلية الدوران			5,200	2,315	2,545	19645
<b>Tramo de pluma</b> <b>Jib section</b> Tronçon de flèche Auslegerabschnitt Секция стрелы أجزاء الذراع	1 2 3 4 5 6 7 8 9-4R		8,884 10,583 10,583 10,583 10,583 10,583 5,406 5,396 1,997	2,271 2,150 1,988 1,988 1,988 1,988 1,988 1,988 2,032	2,259 2,369 2,277 2,404 2,277 2,258 2,270 2,279 3,610	3940 4315 3710 3320 3290 2880 1815 2305 3030
<b>Contrapluma 1 / Counterjib 1</b> Contre-flèche 1 / Gegenausleger 1 / Противовесная консоль 1 / 1 الذراع المعاكس 1 / 1			4,471	2,290	2,540	9915
<b>Contrapluma 2 / Counterjib 2</b> Contre-flèche 2 / Gegenausleger 2 / Противовесная консоль 2 / 2 الذراع المعاكس 2 / 2			4,793	2,290	2,250	8065
<b>Contrapluma 2 + Elevación pluma + pasteca</b> <b>Counterjib 2 + Luffing mech + Reeving block</b> Contre-flèche 2 + Relevage de flèche + Bloc de renvoi Gegenausleger 2 + Auslegerhebewerk + Unterflasche Противовесная консоль 2 + Подъем стрелы + Канифас-болк / الذراع المعاكس 2 + رافع الذراع			5,085	2,665	2,725	19250
<b>Elevación pluma / Luffing mech</b> Relevage de flèche / Auslegerhub / Подъем стрелы			2,860	2,480	2,075	7470
<b>Pasteca / Reeving Block</b> Bloc de renvoi / Unterflasche / Канифас-болк			3,340	1,055	2,050	1875
<b>Mecanismo elevacion carga sin cable / Hoisting mechanism without rope</b> Mécanisme de levage de charge sans câble / Lasthubmechanismus ohne Seil Подъем груза / (without rope) / رافع الحمولة / (without rope)			3,190	2,350	1,980	7500
<b>Polipasto / Hook assembly</b> Palan / Flaschenzug / Полиспаст / بكرة	4R 2R/3R TD		1,380 1,512 0,180	0,525 0,950 0,346	2,600 2,540 2,09	1690 1670 380
<b>Tirante sostén pluma / Jib support tie</b> Tirant de fleche Haltestange Ausleger Растяжка поддержки стрелы / مشد دعامة الذراع			5,416 5,416	0,360 0,360	0,400 0,400	1390 1375
<b>Parte superior + mecanismo auxiliar</b> <b>Top part + auxiliary winch</b> Partie supérieure + mécanisme auxiliaire Oberteil + zusätzlicher Mechanismus			11,825	2,300	1,978	17800



		L (m)	A (m)	H (m)	P/W(kg)
<b>Plataforma y cabina / Platform and cabin</b> Plateforme et cabine / Plattform + Führerstand Платформа и кабина / منصة وكابينة		3,670	2,300	2,480	1250
<b>Contrapeso / Counterweight</b> Contrepoids / Gegengewichte / Противовес / اوزان معاكسة		4,500 2,320	0,235 0,235	1,005 1,005	8000 4000
<b>Transporte torre de montaje</b> <b>Jacking cage transport</b> Transport de tour de montage Transport Montageturm Транспортировка монтажной башни نقل برج التركيب	<b>TM20PASP-5,6 - Package 1.</b> 	11,610	2,220	2,485	11915
	<b>TM20PASP-5,6 - Package 2</b> 	11,670	2,010	2,485	14430

**TREPADO / CLIMBING / TÉLESCOPAGE / KLETTERSYSTEM / ЛЕСТНИЦА / التسلق**

$h_{max}: TSP20-5,6T1 + 6 \times TSP20-5,6 + TSP20-5,6T2$

	▶	■
70 m → H		
h (m)	44,8	
D (m)	14,5 – 20,9	
P (KN)	3000	2720
Rmax (KN)	830	1455

$h_{max}: TSP20-5,6T1 + 6 \times TSP20-5,6 + TSP20-5,6T2$

	▶	■
65 m → H		
h (m)	44,8	
D (m)	14,5 – 20,9	
P (KN)	3105	2785
Rmax (KN)	815	1460

$h_{max}: TSP20-5,6T1 + 6 \times TSP20-5,6 + TSP20-5,6T2$

	▶	■
60 m → H		
h (m)	44,8	
D (m)	14,6 – 20,9	
P (KN)	3255	2775
Rmax (KN)	825	1450

$h_{max}: TSP20-5,6T1 + 6 \times TSP20-5,6 + TSP20-5,6T2$

	▶	■
55 m → H		
h (m)	44,8	
D (m)	13,9 – 20,9	
P (KN)	3355	2715
Rmax (KN)	875	1480

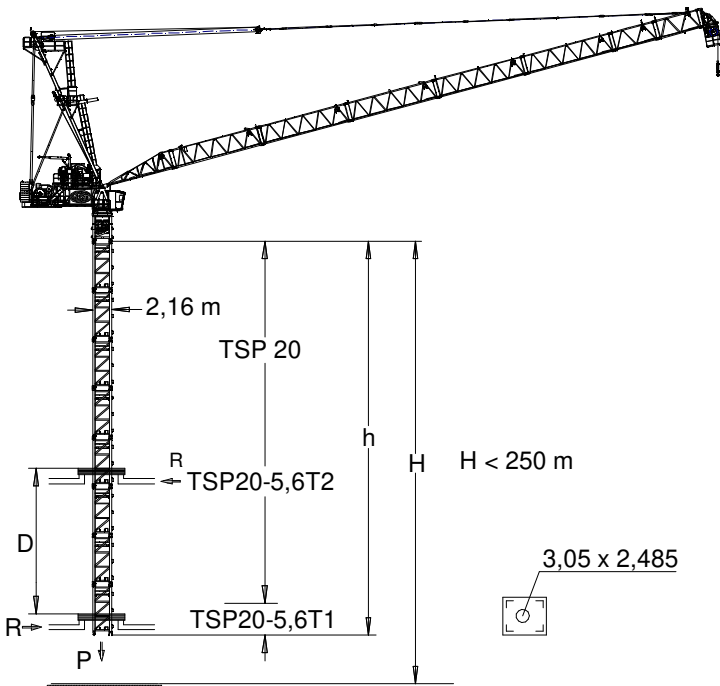

TSP20-5,6T1: 214.31.400  
 TSP20-5,6T2: 214.31.600

**Trepado interno / Internal climbing / Téléscopage / Inneres klettersystem / Внутренняя лестница / التسلق الداخلي**

**Viento fuera de servicio / Out of service wind / Vitesse du vent hors service / Wind außer betrieb / Ветровая нагрузка в покое / الريح خارج الخدمة**

**Consultar / Consult / Nous consulter / Anfragen / Консультируйтесь / الرجوع إلى**

**En servicio / In service / En service / In betrieb / В работе / في الخدمة**

**Fuera de servicio / Out of service / Hors service / Außer betrieb / В покое / خارج الخدمة**

**\* Opcional / Optional / En option / Optional / Опция / اختياري**



Ctra./ Rd. Madrid – Irún - Km. 415 - 20213 IDIAZABAL (Gipuzkoa) - ESPAÑA / SPAIN  
 P.O. Box, 23 - 20.200 - BEASAIN - E-mail: jaso@jaso.com  
 Tel. +34 943 - 18 70 00 • Fax. +34 943 - 18 70 20  
**www.jaso.com**

29/11/2024



**FEM 1005 – C25**

DELEGACIÓN / DEALER

Reservado el derecho a modificaciones sin previo aviso. Declinamos toda responsabilidad derivada de la información proporcionada / Subject to modification, without prior notice. This information is supplied without liability / L'entreprise se réserve le droit de procéder à des modifications sans préavis. Nous déclinons toute responsabilité quant aux informations fournies / Das Recht auf Änderungen ohne vorherige Ankündigung bleibt vorbehalten. Wir übernehmen keine Gewähr für die gemachten Angaben / Мы оставляем за собой право на внесение изменений без предварительного уведомления. Мы снимаем с себя любую ответственность в отношении предоставленной информации / حقوق التغيير محفوظة دون إشعار مسبق. دون أدنى مسؤولية عن المعلومات المقدمة