

H= Máxima altura de torre sin arriostrar (m) / Maximum tower height without fastening (m)

D ■ Distancias fuera de servicio dependen de la altura de la torre / Out of service distances depend on tower height

*Dmin ■ Distancias mínimas fuera de servicio dependen de la altura de la torre / Out of service minimum distances depend on tower height

Tramo pluma 1 / Jib section 1	216.40.000
Tramo pluma 2 / Jib section 2	216.41.000
Tramo pluma 3 / Jib section 3	216.42.000
Tramo pluma 4 / Jib section 4	216.43.000
Tramo pluma 5 / Jib section 5	216.44.000

Tramo pluma 6 / Jib section 6	216.45.000
Tramo pluma 7 / Jib section 7	216.46.000
Tramo pluma 8 / Jib section 8	206.47.200
Tramo pluma 9 / Jib section 9	212.48.000

TR24-5,6	206.32.000
TRD24-5,6	206.32.300
TRID24-5,6	156.30.800
TR24/TSR20	204.36.500

CUSTOMIZE YOUR CRANE

OPTIMUS
line JASD



OPTI Cube



TC Diagnosis SYSTEM



CLIMBING Solution



SAFETY Pack



Customization



ECO Mode



COMFORT Cabin



HIGH POWER Motors



JL25 Tower Crane Elevator



SMARTLINK
BE SMART keep control

*Dmin ■

(H) ESTACIONARIA / STATIONARY

TD

TD / 2R

▽▽	H(ft)	D■(ft)	☒	≡
213	152	66	8	1
197	152	69	8	1
180	171	72	9	1
164	171	75	9	1
148	189	79	10	1
131	207	82	11	1
115	207	79	11	1
98	207	82	11	1

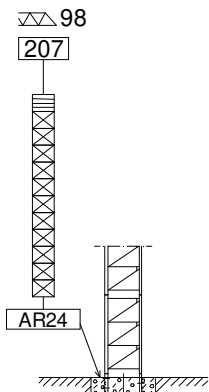

▽▽	H(ft)	D■(ft)	☒	≡
213	152	66	8	1
197	152	69	8	1
180	152	72	8	1
164	152	75	8	1
148	152	79	8	1
131	152	85	8	1
115	152	85	8	1
98	152	92	8	1

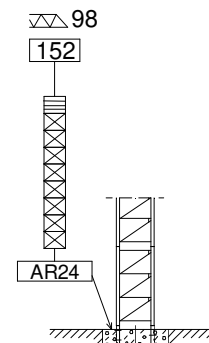

(H) ESTACIONARIA 3 / STATIONARY 3

TD

TD / 2R

▽▽	H(ft)	D■(ft)	☒	≡
213	174	66	8	1
197	174	69	8	1
180	193	72	9	1
164	193	75	9	1
148	211	79	10	1
131	230	82	11	1
115	230	79	11	1
98	230	82	11	1

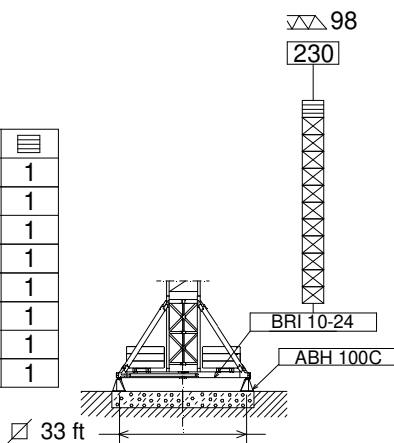

▽▽	H(ft)	D■(ft)	☒	≡
213	174	66	8	1
197	174	69	8	1
180	174	72	8	1
164	174	75	8	1
148	174	79	8	1
131	174	85	8	1
115	174	85	8	1
98	174	92	8	1

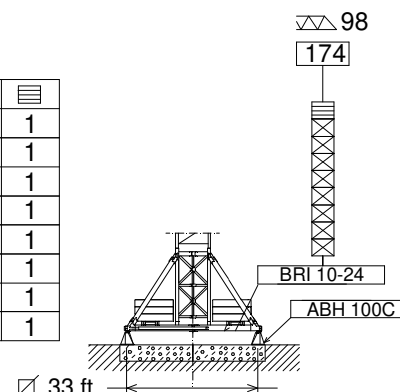

(H) TRASLACION / TRAVELLING

TD

TD / 2R

▽▽	H(ft)	D■(ft)	☒	≡
213	177	66	8	1
197	177	69	8	1
180	195	72	9	1
164	195	75	9	1
148	214	79	10	1
131	232	82	11	1
115	232	79	11	1
98	232	82	11	1

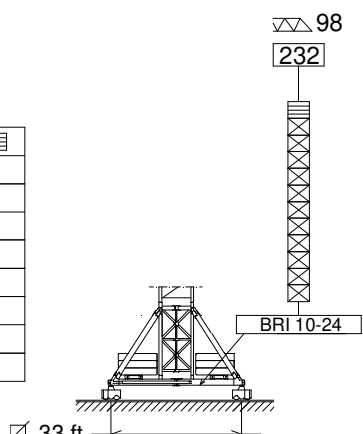

▽▽	H(ft)	D■(ft)	☒	≡
65	177	66	8	1
60	177	69	8	1
55	177	72	8	1
50	177	75	8	1
45	177	79	8	1
40	177	85	8	1
35	177	85	8	1
30	177	92	8	1

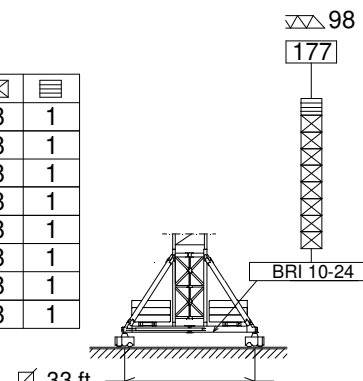

≡ TR24/TSR20 ☒ TR24-5,6

ASRD 20/24 156.21.000
AR24 156.21.200

BRI 10-24 156.20.500
ABH 100C 170.23.000

H= Máxima altura de torre sin arristrar (m). / Maximum tower height without fastening (m).

CARGAS / LOADS

J638PA



TD - 35300 lb

	TD 35300 lb @ (ft)	82	98	115	131	148	164	180	197	213
213	143	35300	35300	35300	35300	33300	27800	23100	19200	15900
197	146	35300	35300	35300	35300	34400	28900	24300	20300	—
180	148	35300	35300	35300	35300	35300	29500	24900	—	—
164	151	35300	35300	35300	35300	35300	30600	—	—	—
148	148	35300	35300	35300	35300	35300	—	—	—	—
131	131	35300	35300	35300	35300	—	—	—	—	—
115	115	35300	35300	35300	—	—	—	—	—	—
98	98	35300	35300	—	—	—	—	—	—	—

CARGAS / LOADS

J638PA



TD/2R - 35300 / 70500 (lb)

	2R 70500 lb @ (ft)	TD 35300 lb @ (ft)	66	82	98	115	131	148	164	180	197	213
213		138	35300	35300	35300	35300	35300	31500	26000	21400	17600	14300
197		141	35300	35300	35300	35300	35300	32800	27300	22700	18700	—
180	88	143	70500	70500	61100	49400	40600	33700	28000	23400	—	—
164	90	146	70500	70500	62400	50700	41700	34800	29100	—	—	—
148	92	148	70500	70500	64400	52500	43400	36400	—	—	—	—
131	94	131	70500	70500	66600	54500	45200	—	—	—	—	—
115	96	115	70500	70500	68800	56400	—	—	—	—	—	—
98	98	98	70500	70500	70500	—	—	—	—	—	—	—

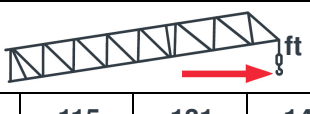
	2R 39700 lb @ (ft)	TD 19800 lb @ (ft)										
			82	98	115	131	148	164	180	197	213	
213	128	190	39700	39700	39700	39500	31500	26000	21400	17600	14300	

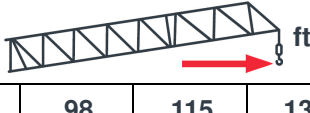
	2R 57300 lb @ (ft)	TD 28700 lb @ (ft)										
			66	82	98	115	131	148	164	180	197	
197	102	159	57300	57300	57300	48500	39700	32800	27300	22700	18700	

Datos válidos para / Valid data for:



2R H ≤ 361 ft
TD H ≤ 722 ft

 **FEM 1001**



Reservado el derecho a modificaciones sin previo aviso. Declinamos toda responsabilidad derivada de la información proporcionada / Subject to modification, without prior notice. This information is supplied without liability



EC150152VF
110 kW

*** EC180188VF**
132 kW

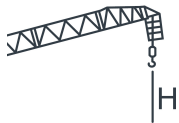
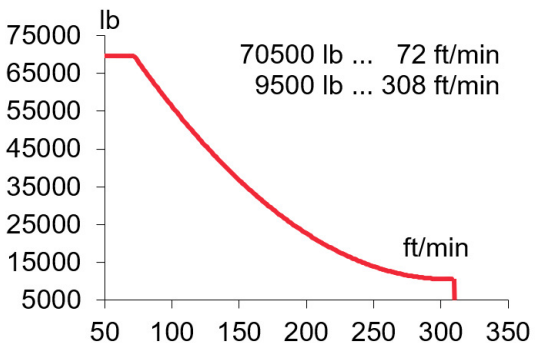
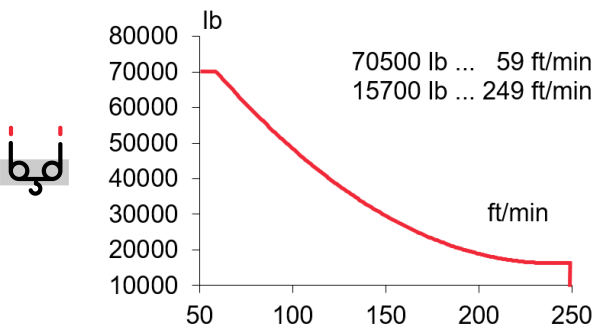
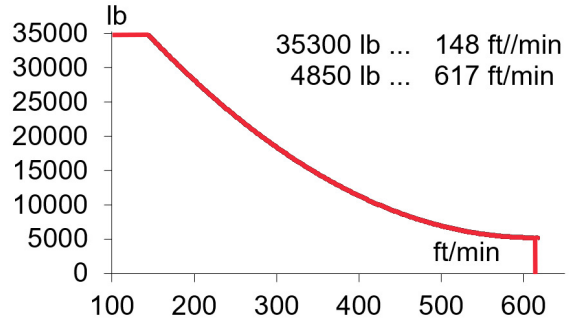
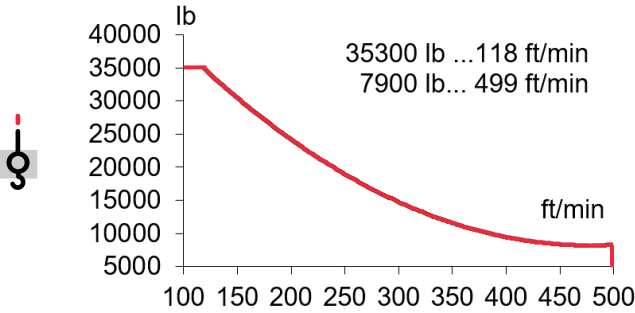

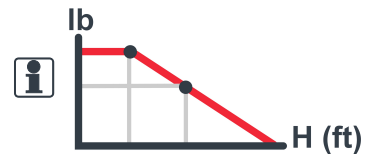

$H \leq \frac{TD}{2R}$
2133 ft
1066 ft



<p>OG2008VF 2 X 7,3 kW</p>	<p>EP10015VF 75 kW</p>	<p>TG4025VF 4 x 7,5 kW</p>	<p>TH2506 18,4 kW</p>
<p>0...0,8 r/min sl/min</p>	<p>1,5 min</p>	<p>0...82 ft/min</p>	<p>2 ft/min</p>

3~ 400V 50Hz
480V 60Hz

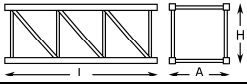
KVA			
EC150152VF	136	162	189
EC180188VF	147	179	210

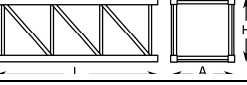
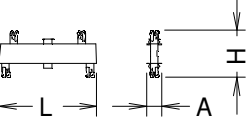
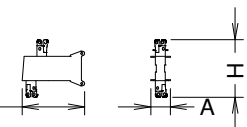
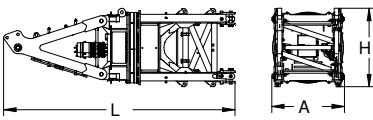
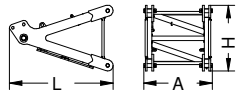
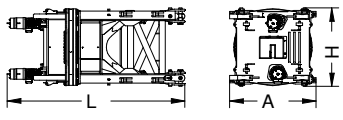
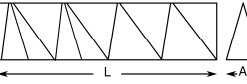
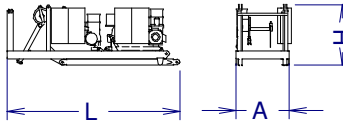
		L (ft)	A (ft)	H (ft)	P/W(lb)	
Torre inferior / Lower tower	TRID24-5,6		19.7	7.0	7.1	18190
Torre desmontada / Dismantled tower	TRD24-5,6		19.7	8.3	3.9	10850
Torre / Tower	TR24-5,6		19.7	8.9	9.2	9900
Larguero largo, reducción Long crossbar, reduction	TR24/TSR20		15.9	2.1	5.5	6280
Larguero corto reducción Short crossbar, reduction	TR24/TSR20		7.8	1.9	5.5	3190
Torre asiento pista, torre superior y orientación Slewing table, top tower and slewing mechanism		24.7	7.8	8.3	46520	
Punta de torre / Tower head		11.0	7.3	6.8	12790	
Torre asiento pista + base punta de torre + orientación Slewing table + tower head base + slewing mechanism		17.1	8.3	7.8	27560	
Tramo de pluma Jib section	1 2 3 4 5 6 7 8 9		20.3 34.3 34.5 34.6 34.6 34.6 18.4 12.2 6.6	7.1 5.0 5.0 5.0 4.9 4.9 4.9 4.9 6.2	5.8 5.7 5.7 5.7 5.7 5.7 5.7 6.1 6.7	4030 5560 5270 4760 4320 3860 2270 2250 2230
Contrapluma con mecanismos, pasteca y plumin (sin cable de elevación) / Counterjib with mechanisms, reeving block and auxiliary jib (without hoisting rope)		29.9	7.8	9.1	54450	

LISTA DE EMBARQUE / PACKING LIST

J638PA

		L (ft)	A (ft)	H (ft)	P/W(lb)
Contrapluma con elevacion pluma, pasteca y plumin Counterjib+ luffing mechanisms+ reeving block + auxiliary jib		29.9	7.2	8.4	36380
Mecanismo elevacion carga sin cable / Hoisting mechanism without rope		8.0	8.1	7.1	17920
Polipasto / Hook assembly	TD/2R TD 	3.3 0.6	1.4 1.1	6.5 6.9	1730 840
Tirante sostén pluma / Jib support tie		17.7	1.4	2.0	4740
Parte superior / Top part		39.2	7.2	6.8	28880
Plataforma y cabina / Platform and cabin		12.0	6.3	8.1	2760
Contrapeso / Counterweight Lastre / Ballast		12.5	1.9	4.9	13230

TRANSPORTE / TRANSPORT

J638PA

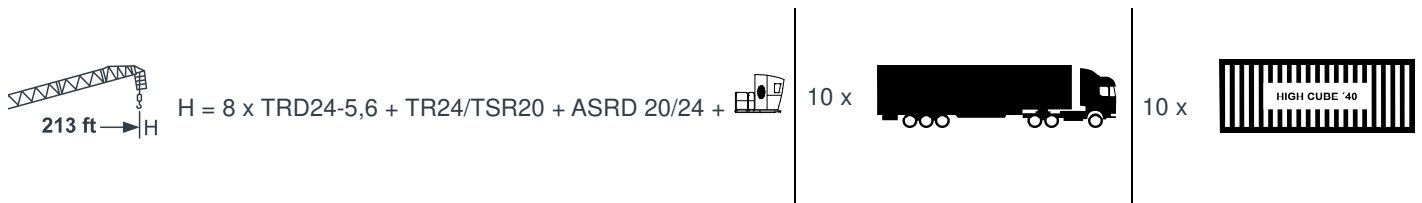

	Viento fuera de servicio / Out of service wind
	Consultar / Consult
	En servicio / In service
	Fuera de servicio / Out of service
	Opcional / Optional



Ctra./ Rd. Madrid – Irún - Km. 415 - 20213 IDIAZABAL (Gipuzkoa) - ESPAÑA / SPAIN
 P.O. Box, 23 - 20.200 - BEASAIN - E-mail: jaso@jaso.com
 Tel. +34 943 - 18 70 00 • Fax. +34 943 - 18 70 20
www.jaso.com

31/03/2025

FEM 1001

DELEGACIÓN / DEALER