



UNE 58-101
FEM 1001

J638PA

GRUA TORRE / TOWER CRANE
GRUE A TOUR / TURMDREHKRAN / БАШЕННЫЙ КРАН / رافعة برجية

FEM 1001

UNE-EN-ISO 9001

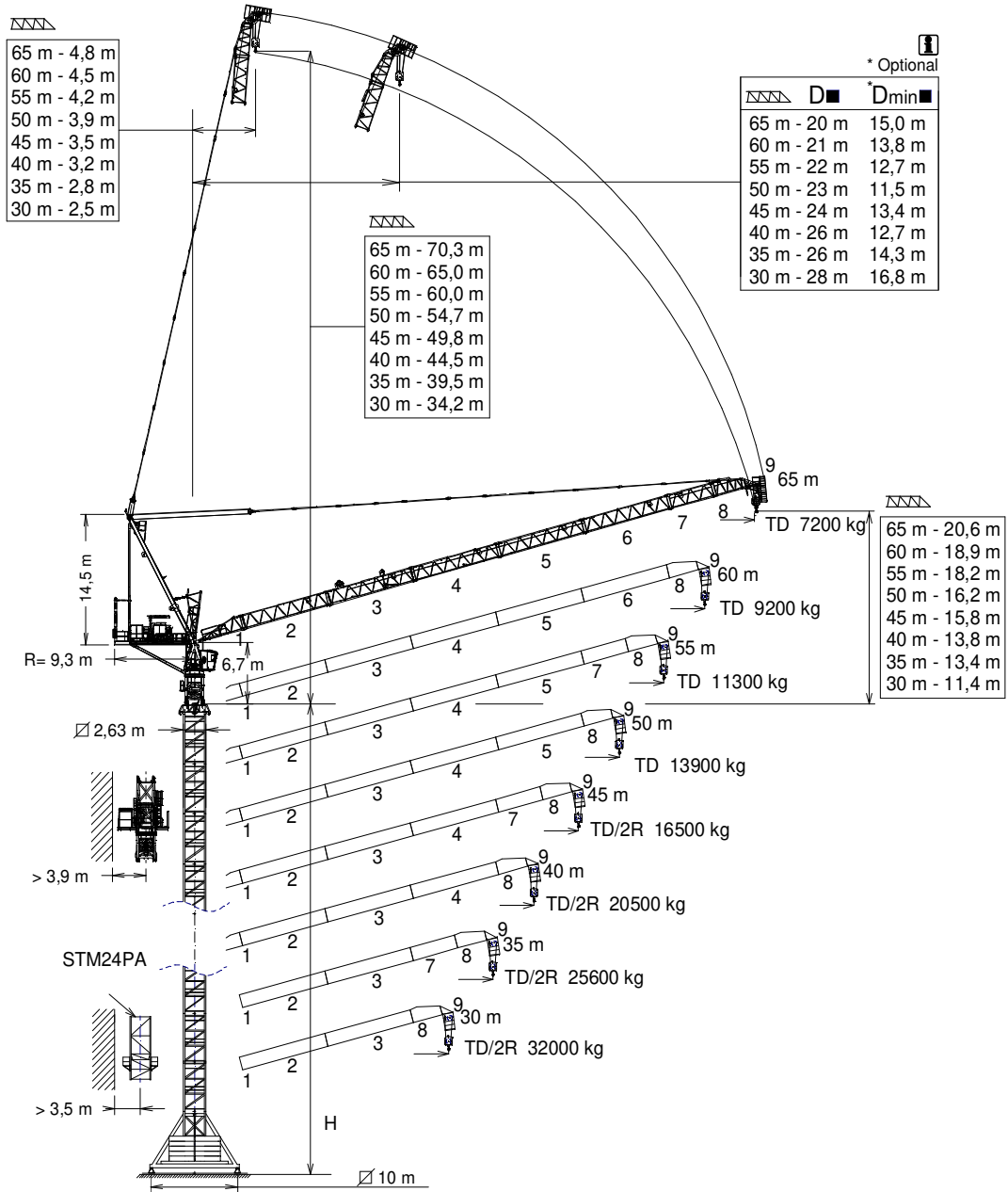

H= Máxima altura de torre sin arriostrar (m). / Maximum tower height without fastening (m)

Hauteur maximale de tour sans ancrage (m). / Maximale Höhe ohne Verstreben (m) / Максимальная высота башни без крепления (м). / أقصى ارتفاع للبرج بدون ربط (م)

D Distancias fuera de servicio dependen de la altura de la torre / Out of service distances depend on tower height / Distances hors service dépendent de la hauteur de la tour / Die Außerbetriebnahmebereiche hängen von der Höhe des Turms ab

***Dmin** Distancias mínimas fuera de servicio dependen de la altura de la torre / Out of service minimum distances depend on tower height / Distances minimales hors service dépendent de la hauteur de la tour / Die Mindestabstände außer Betrieb von der Höhe des Turms ab

Tramo pluma 1 / Jib section 1	216.40.000
Tramo pluma 2 / Jib section 2	216.41.000
Tramo pluma 3 / Jib section 3	216.42.000
Tramo pluma 4 / Jib section 4	216.43.000
Tramo pluma 5 / Jib section 5	216.44.000

Tramo pluma 6 / Jib section 6	216.45.000
Tramo pluma 7 / Jib section 7	216.46.000
Tramo pluma 8 / Jib section 8	206.47.200
Tramo pluma 9 / Jib section 9	212.48.000

TR24-5,6	206.32.000
TRD24-5,6	206.32.300
TRID24-5,6	156.30.800
TR24/TSR20	204.36.500

CUSTOMIZE YOUR CRANE

OPTIMUS
line



OPTI Cube



TC Diagnosis SYSTEM



CLIMBING Solution



SAFETY Pack



Customization



ECO Mode



COMFORT Cabin



HIGH POWER Motors



JL25 Tower Crane Elevator



BE SMART keep control



Reservado el derecho a modificaciones sin previo aviso. Declinamos toda responsabilidad derivada de la información proporcionada / Subject to modification, without prior notice. This information is supplied without liability / L'entreprise se réserve le droit de procéder à des modifications sans préavis. Nous déclinons toute responsabilité quant aux informations fournies / Das Recht auf Änderungen ohne vorherige Ankündigung bleibt vorbehalten. Wir übernehmen keine Gewähr für die gemachten Angaben / Мы оставляем за собой право на внесение изменений без предварительного уведомления. Мы снимаем с себя любую ответственность в отношении предоставленной информации / حقوق التغيير محفوظة دون إشعار مسبق. دون أدنى مسؤولية عن المعلومات المقدمة

*Dmin ■

(H) ESTACIONARIA / STATIONARY / STATIONAIRE / STATIONÄR / СТАЦИОНАРНОЕ СОСТОЯНИЕ / ثابتة

TD

TD / 2R

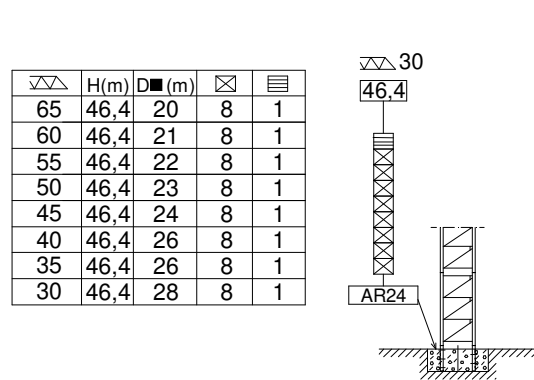
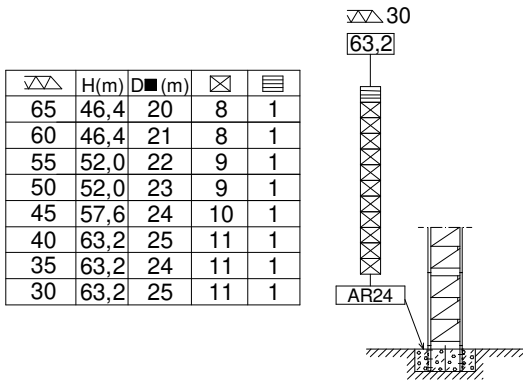

(H) ESTACIONARIA 3 / STATIONARY 3 / STATIONAIRE 3 / STATIONÄR 3 / СТАЦИОНАРНОЕ СОСТОЯНИЕ / ثابتة

TD

TD / 2R

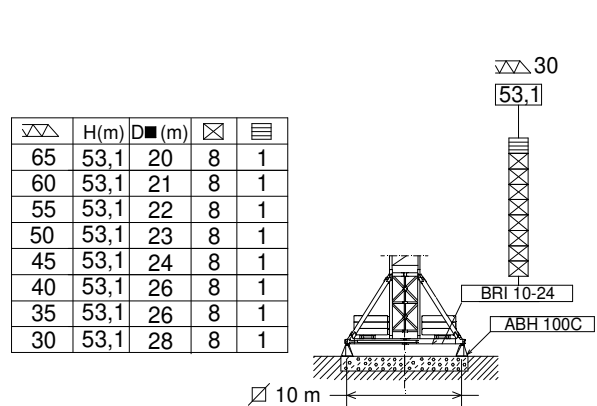
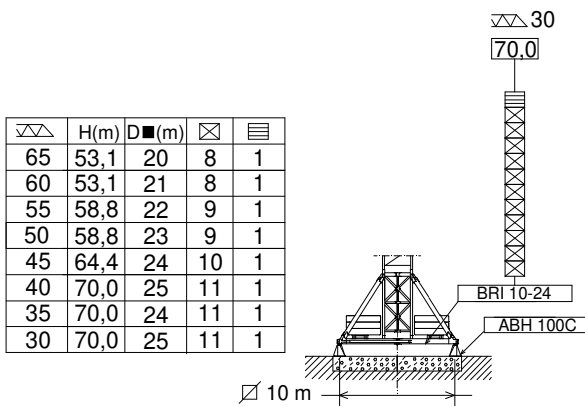

(H) TRASLACION / TRAVELLING / TRASLATION / FORTBEWEGUNG / ПЕРЕМЕЩЕНИЕ / متحركة

TD

TD / 2R

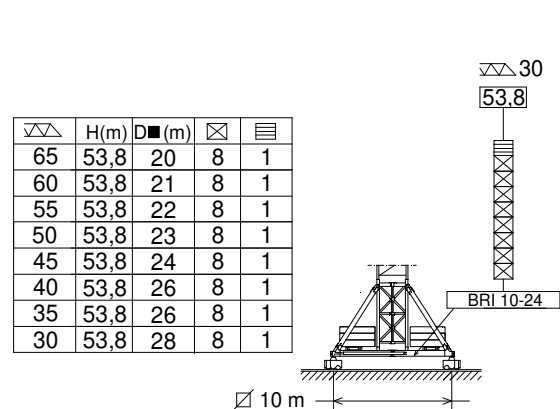
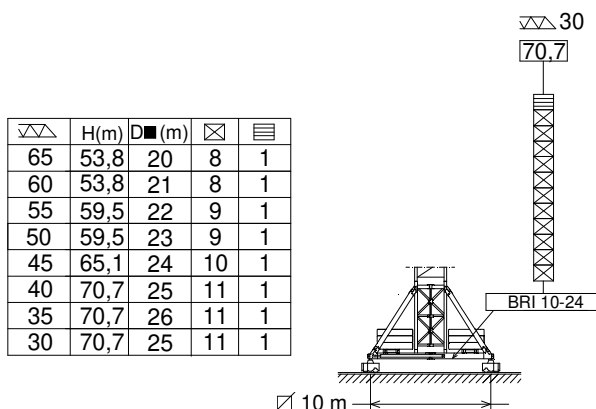

☒ TR24/TSR20

☒ TR24-5,6

ASRD 20/24 156.21.000
AR24 156.21.200

BRI 10-24 156.20.500
ABH 100C 170.23.000

H= Máxima altura de torre sin arriostrar (m). / Maximum tower height without fastening (m).

Hauteur maximale de tour sans ancrage (m). / Maximale Höhe ohne Verstreben (m) / Максимальная высота башни без крепления (м). / أقصى ارتفاع للبرج بدون ربط (م)



TD - 16 t



	TD 16 t @ ...(m)	25	30	35	40	45	50	55	60	65
65	43,5	16,0	16,0	16,0	16,0	15,1	12,6	10,5	8,7	7,2
60	44,4	16,0	16,0	16,0	16,0	15,6	13,1	11,0	9,2	—
55	45,0	16,0	16,0	16,0	16,0	16,0	13,4	11,3	—	—
50	45,9	16,0	16,0	16,0	16,0	16,0	13,9	—	—	—
45	45,0	16,0	16,0	16,0	16,0	16,0	—	—	—	—
40	40,0	16,0	16,0	16,0	16,0	—	—	—	—	—
35	35,0	16,0	16,0	16,0	—	—	—	—	—	—
30	30,0	16,0	16,0	—	—	—	—	—	—	—

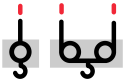

TD/2R - 16 / 32 (t)



	2R 32 t @ (m)	TD 16 t @ (m)	20	25	30	35	40	45	50	55	60	65
65		42,1	16,0	16,0	16,0	16,0	16,0	14,3	11,8	9,7	8,0	6,5
60		43,0	16,0	16,0	16,0	16,0	16,0	14,9	12,4	10,3	8,5	—
55	26,9	43,7	32,0	32,0	27,7	22,4	18,4	15,3	12,7	10,6	—	—
50	27,3	44,6	32,0	32,0	28,3	23,0	18,9	15,8	13,2	—	—	—
45	28,0	45,0	32,0	32,0	29,2	23,8	19,7	16,5	—	—	—	—
40	28,6	40,0	32,0	32,0	30,2	24,7	20,5	—	—	—	—	—
35	29,4	35,0	32,0	32,0	31,2	25,6	—	—	—	—	—	—
30	30,0	30,0	32,0	32,0	32,0	—	—	—	—	—	—	—

	2R 18 t @ (m)	TD 9 t @ (m)	25	30	35	40	45	50	55	60	65
65	39,1	58,0	18,0	18,0	18,0	17,9	14,3	11,8	9,7	8,0	6,5

	2R 26 t @ (m)	TD 13 t @ (m)	20	25	30	35	40	45	50	55	60
60	31,0	48,6	26,0	26,0	26,0	22,0	18,0	14,9	12,4	10,3	8,5

Datos válidos para / Valid data for
Donnees valables pour / Gultige Daten für / Допустимые данные для / البيانات الصالحة لـ



2R H ≤ 110 m
TD H ≤ 220 m



FEM 1001



Reservado el derecho a modificaciones sin previo aviso. Declinamos toda responsabilidad derivada de la información proporcionada / Subject to modification, without prior notice. This information is supplied without liability. L'entreprise se réserve le droit de procéder à des modifications sans préavis. Nous déclinons toute responsabilité quant aux informations fournies / Das Recht auf Änderungen ohne vorherige Ankündigung bleibt vorbehalten. Wir übernehmen keine Gewähr für die gemachten Angaben / Мы оставляем за собой право на внесение изменений без предварительного уведомления. Мы снимаем с себя любую ответственность отнютии предоставленной информации / حقوق التغيير محفوظة دون إشعار مسبق. دون أننى مسؤولية عن المعلومات المقدمة.



EC150152VF
110 kW

*** EC180188VF**
132 kW

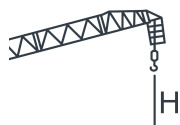
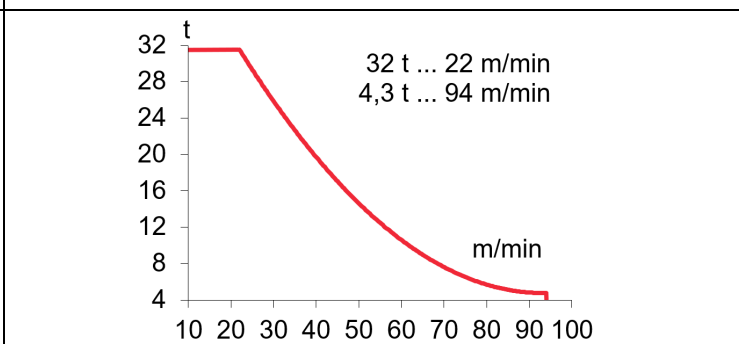
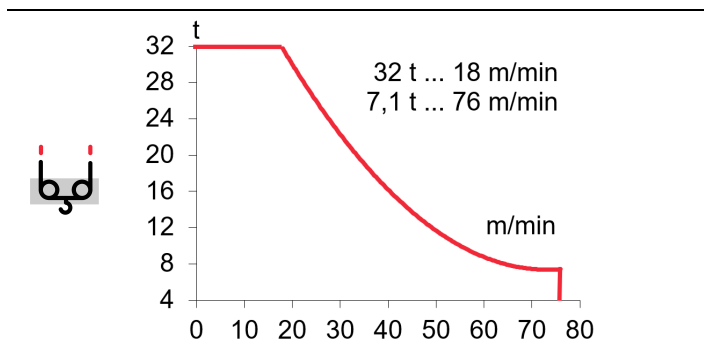
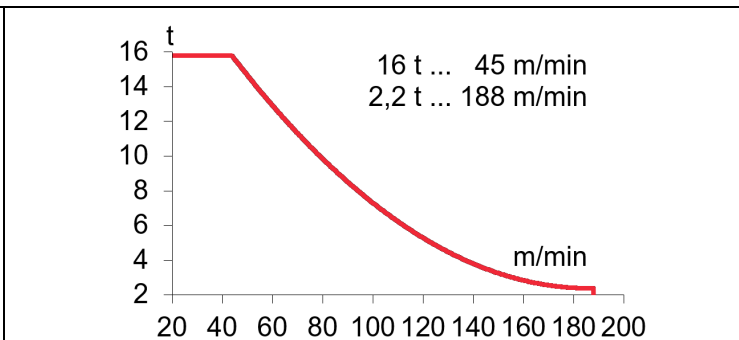
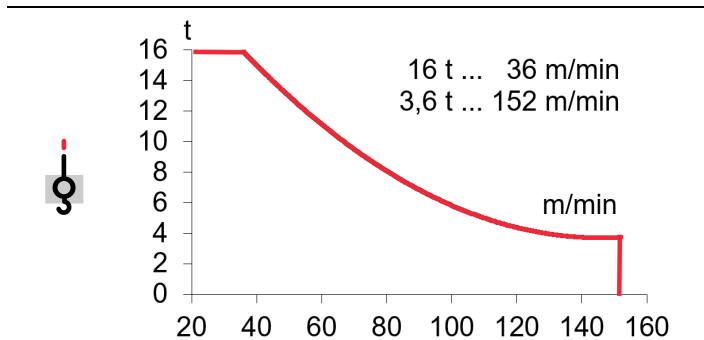

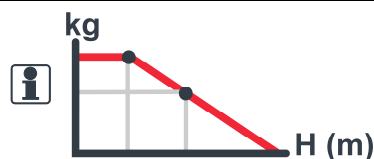

$H \leq \begin{matrix} TD & 650 \text{ m} \\ 2R & 325 \text{ m} \end{matrix}$



OG2008VF 2 X 7,3 kW	EP10015VF 75 kW	TG4025VF 4 x 7,5 kW	TH2506 18,4 kW
0...0,8 r/min sl/min	1,5 min	0...25 m/min	0,6 m/min

3~ 400V 50Hz
480V 60Hz

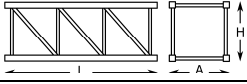
KVA			
EC150152VF	136	162	189
EC180188VF	147	179	210

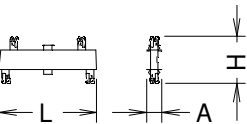
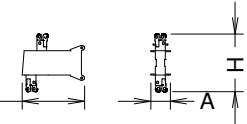
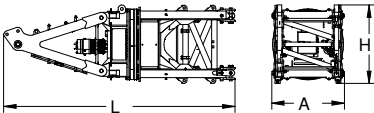
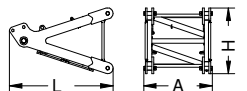
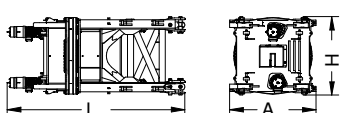
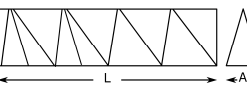
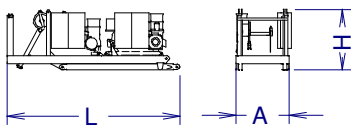
			L (m)	A (m)	H (m)	P/W(kg)
Torre inferior / Lower tower Tour inférieure / Unterer Turm Нижняя башня / البرج السفلى	TRID24-5,6		5,990	2,142	2,164	8250
Torre desmontada / Dismantled tower Tour démontée / Demontierter Turm Разобранная башня / برج مفكك	TRD24-5,6		5,990	2,530	1,180	4920
Torre / Tower Tour / Turm / Башня / برج	TR24-5,6		5,990	2,720	2,815	4490
Larguero largo, reducción Long crossbar, reduction Traverse longue, réduction Langer Längsträger, Reduzierung Длинная продольная балка عارضضة طويلة، مُصغّر	TR24/TSR20		4,856	0,630	1,670	2850
Larguero corto reducción Short crossbar, reduction Traverse courte, réduction Kurzer Längsträger, Reduzierung Короткая продольная балка, уменьшение / عارضضة قصيرة، مُصغّر	TR24/TSR20		2,370	0,564	1,670	1445
Torre asiento pista, torre superior y orientación Slewing table, top tower and slewing mechanism Tour pivot + tour supérieure + mécanisme d'orientation Turmsitz + oberer Turm + Ausrichtung Сиденье площадки + верхняя башня + поворотный механизм برج وحدة الدوران + البرج العلوي + آلية الدوران			7,526	2,365	2,544	21100
Punta de torre / Tower head / Porte-flèche Turmspizze / верхняя секция башни / رأس البرج			3,356	2,220	2,077	5800
Torre asiento pista + base punta de torre + orientación Slewing table + tower head base + slewing mechanism Tour pivot + base du porte-flèche + mécanisme d'orientation Turmsitz + Turmspitzbasis + Ausrichtung Сиденье площадки + основание верхней секции башни + поворотный механизм برج وحدة الدوران + قاعدة رأس البرج + آلية الدوران			5,225	2,544	2,365	12500
Tramo de pluma Jib section Tronçon de flèche Auslegerabschnitt Секция стрелы أجزاء الذراع	1 2 3 4 5 6 7 8 9		6,186 10,460 10,505 10,550 10,550 10,550 5,615 3,720 2,010	2,160 1,530 1,530 1,530 1,500 1,500 1,500 1,500 1,900	1,760 1,740 1,750 1,750 1,730 1,725 1,725 1,855 2,050	1830 2600 2660 2180 1960 1750 1040 1020 1010
Contrapluma con mecanismos, pasteca y plumin Counterjib with mechanisms, reeving block and auxiliary jib Contre-flèche avec mécanismes et fléchette auxiliaire Gegenausleger + Mechanismus + Unterflasche + Ausleger Противовесная консоль с механизмами и вспомогательной الذراع المعاكس مع آليات وريشة مساعدة			9,105	2,375	2,765	21400

LISTA DE EMBARQUE / PACKING LIST

LISTE DE COLISAGE / KOLLI LISTE / СПИСОК ПОСТАВКИ / قائمة التحميل

J638PA

		L (m)	A (m)	H (m)	P/W(kg)
Contrapluma con elevacion pluma, pasteca y plumin Counterjib+ luffing mechanisms+ reeving block+ auxiliary jib Contre-flèche avec mécanisme de relevage de la flèche, moufle et fléchette Gegenausleger + Auslegerhebewerk + Unterflasche + Ausleger Противовесная консоль с механизмом подъема стрелы, блоком и дополнительной стрелой الذراع المعاكس مع رافع الذراع والبكرة والريشة الإضافية		9,105	2,200	2,555	14300
Mecanismo elevacion carga / Hoisting mechanism Mécanisme de levage de charge Lasthubmechanismus رفع الحمولة / رفع الحمولة		2,650	2,470	2,170	8690
Polipasto / Hook assembly Palan / Flaschenzug Полиспаст / بكرة	TD/2R TD 	1,010 0,180	0,414 0,3458	1,985 2,090	785 380
Tirante sostén pluma / Jib support tie Tirant de fleche Haltestange Ausleger Растяжка поддержки / مشد دعامة الذراع		5,410	0,430	0,615	2100
Parte superior / Top part Partie supérieure / Oberteil		12,469	2,310	2,261	12300
Plataforma y cabina / Platform and cabin Plateforme et cabine / Plattform + Führerstand Платформа и кабина / منصة وكابينة		3,670	1,925	2,480	1130
Contrapeso / Counterweight Contrepoids / Gegengewicht Противовес / اوزان معاكسة	Lastre / Ballast / Lest Ballast / Балласт / ثقل 	3,800	0,580	1,500	6000

TRANSPORTE / TRANSPORT / TRANSPORT / TRANSPORT / ТРАНСПОРТИРОВКА / نقل

J638PA



65 m

H = 8 x TR24-5,6 + TR24/TSR20 + ASRD 20/24 +

10 x



10 x



Viento fuera de servicio / Out of service wind / Vitesse du vent hors service / Wind außer betrieb / Ветровая нагрузка в покое / الريح خارج الخدمة

Consultar / Consult / Nous consulter / Anfragen / Консультируйтесь / الرجوع إلى

En servicio / In service / En service / In betrieb / В работе / في الخدمة

Fuera de servicio / Out of service / Hors service / Außer betrieb / В покое / خارج الخدمة

Opcional / Optional / En option / Optional / Опция / اختياري



Ctra./ Rd. Madrid – Irún - Km. 415 - 20213 IDIAZABAL (Gipuzkoa) - ESPAÑA / SPAIN

P.O. Box, 23 - 20.200 - BEASAIN - E-mail: jaso@jaso.com

Tel. +34 943 - 18 70 00 • Fax. +34 943 - 18 70 20

www.jaso.com

29/11/2024

FEM 1001

DELEGACIÓN / DEALER

Reservado el derecho a modificaciones sin previo aviso. Declinamos toda responsabilidad derivada de la información proporcionada / Subject to modification, without prior notice. This information is supplied without liability / L'entreprise se réserve le droit de procéder à des modifications sans préavis. Nous déclinons toute responsabilité quant aux informations fournies / Das Recht auf Änderungen ohne vorherige Ankündigung bleibt vorbehalten. Wir übernehmen keine Gewähr für die gemachten Angaben / Мы оставляем за собой право на внесение изменений без предварительного уведомления. Мы снимаем с себя любую ответственность в отношении предоставленной информации / حقوق التغيير محفوظة دون إشعار مسبق. دون أدنى مسؤولية عن المعلومات المقدمة