



EN 14439
C25

J480PA

GRUA TORRE / TOWER CRANE
GRUE A TOUR / TURMDREHKRAN / БАШЕННЫЙ КРАН / رافعة برجية

FEM 1005 - C25

UNE-EN-ISO 9001

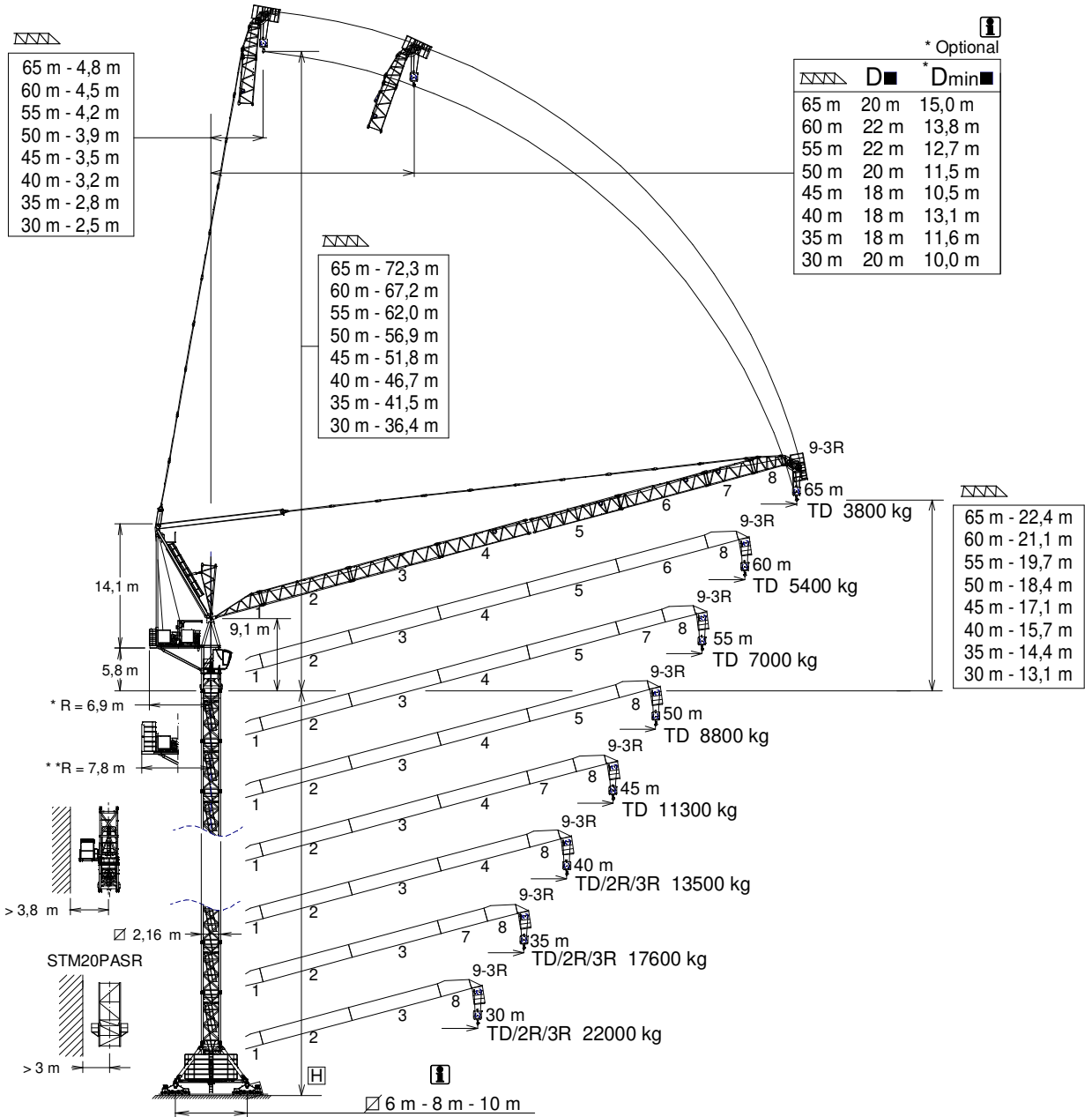

* Contrapesos metálicos / Steel Counterweight ** Contrapesos de hormigón / Concrete counterweights
Tramo pluma / Jib section / Tronçon de fleche / Auslegerabschnitt / Секция стрелы / أجزاء الذراع

D ■ Distancias fuera de servicio dependen de la altura de la torre / Out of service distances depend on tower height / Distances hors service dépendent de la hauteur de la tour / Die Außerbetriebnahmereichweiten hängen von der Höhe des Turms ab

*Dmin ■ Distancias mínimas fuera de servicio dependen de la altura de la torre / Out of service minimum distances depend on tower height / Distances minimales hors service dépendent de la hauteur de la tour / Die Mindestabstände außer Betrieb von der Höhe des Turms ab

CUSTOMIZE YOUR CRANE

OPTIMUS
line JASD



OPTI Cube



TC Diagnosis SYSTEM



CLIMBING Solution



SAFETY Pack



Customization



ECO Mode



COMFORT Cabin



HIGH POWER Motors



JL25 Tower Crane Elevator



SMARTLINK

BE SMART keep control



Reservado el derecho a modificaciones sin previo aviso. Declinamos toda responsabilidad derivada de la información proporcionada / Subject to modification, without prior notice. This information is supplied without liability / L'entreprise se réserve le droit de procéder à des modifications sans préavis. Nous déclinons toute responsabilité quant aux informations fournies / Das Recht auf Änderungen ohne vorherige Ankündigung bleibt vorbehalten. Wir übernehmen keine Gewähr für die gemachten Angaben / Мы оставляем за собой право на внесение изменений без предварительного уведомления. Мы снимаем с себя любую ответственность в отношении предоставленной информации / حقوق التغيير محفوظة دون إشعار مسبق دون أدنى مسؤولية عن المعلومات المقدمة

29/11/2024



	TD 12 t @ ...(m)	30	35	40	45	50	55	60	65
65	41,1	12,0	12,0	12,0	10,1	8,0	6,4	5,0	3,8
60	41,9	12,0	12,0	12,0	10,5	8,5	6,8	5,4	—
55	42,2	12,0	12,0	12,0	10,7	8,6	7,0	—	—
50	42,4	12,0	12,0	12,0	10,8	8,8	—	—	—
45	43,5	12,0	12,0	12,0	11,3	—	—	—	—
40	40,0	12,0	12,0	12,0	—	—	—	—	—
35	35,0	12,0	12,0	—	—	—	—	—	—
30	30,0	12,0	—	—	—	—	—	—	—



	3R 36 t @ (m)	2R 24 t @ (m)	TD 12 t @ (m)	15	20	25	30	35	40	45	50	55	60	65
65	36 t @ (m)	26,4	40,3	12,0	12,0	12,0	12,0	12,0	12,0	9,6	7,6	5,9	4,5	3,3
60		26,4	41,0	24,0	24,0	24,0	19,9	15,6	12,4	9,9	7,9	6,3	4,9	—
55		26,4	41,3	24,0	24,0	24,0	20,0	15,7	12,6	10,1	8,1	6,5	—	—
50	19,3	26,4	41,5	36,0	34,4	25,7	20,0	15,8	12,7	10,2	8,3	—	—	—
45	19,6	26,9	42,5	36,0	35,1	26,4	20,5	16,4	13,2	10,8	—	—	—	—
40	19,7	27,1	40,0	36,0	35,3	26,6	20,8	16,6	13,5	—	—	—	—	—
35	20,2	27,9	35,0	36,0	36,0	27,6	21,8	17,6	—	—	—	—	—	—
30	20,3	28,1	30,0	36,0	36,0	27,9	22,0	—	—	—	—	—	—	—

	2R 18 t @ (m)	TD 9 t @ (m)	25	30	35	40	45	50	55	60	65
65	31,7	46,4	18,0	18,0	15,3	12,0	9,6	7,6	5,9	4,5	3,3

	3R 30 t @ (m)	2R 20 t @ (m)	TD 10 t @ (m)	20	25	30	35	40	45	50	55
55	22,4	30,1	45,5	30,0	25,9	20,0	15,7	12,6	10,1	8,1	6,5

Datos válidos para / Valid data for
Donnees valables pour / Gultige Daten für / Допустимые данные для / البيانات الصالحة لـ

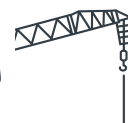

3R H ≤ 110 m
2R TD H ≤ 120 m



EC88115VF
65 kW

***EC150218VF**
110 kW

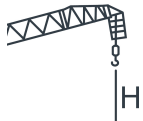
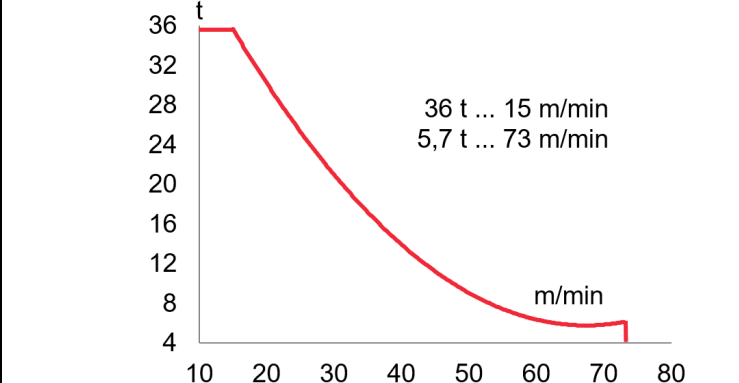
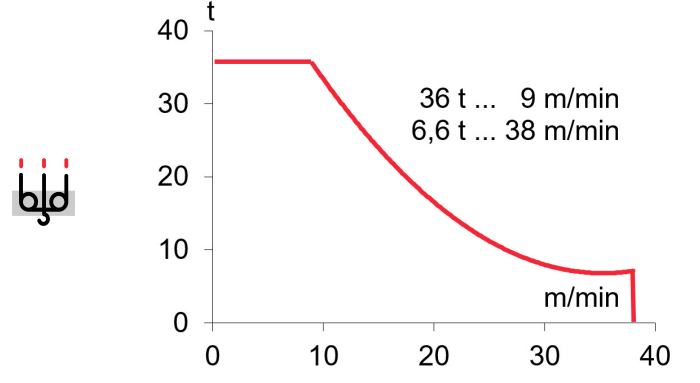
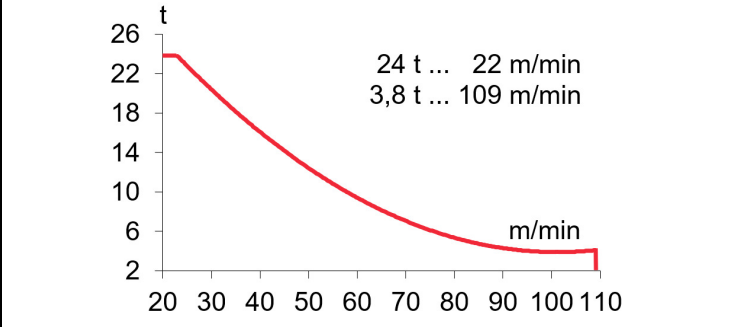
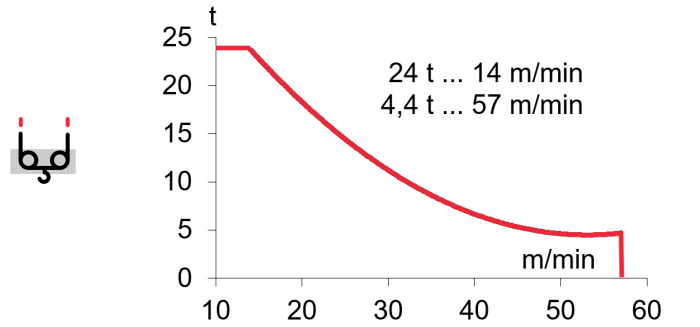
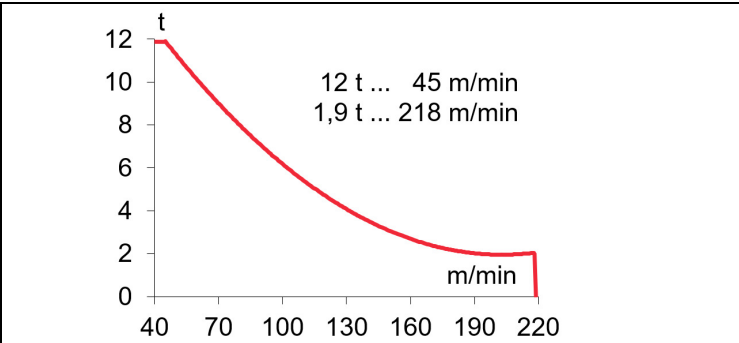
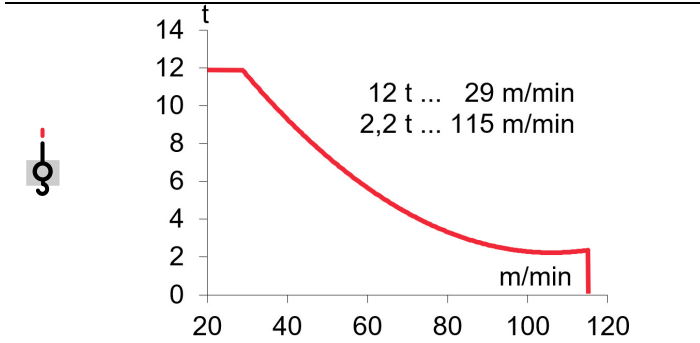

TD 874 m
H ≤ 2R 437 m
3R 291 m



1129 m

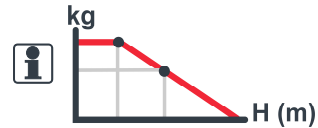

OG2008VF
2 x 7,3 kW

0...0,8 r/min
sl/min

EP10015VF
75 kW

1,5 min

TG4025VF
4 x 7,5 kW

0...25 m/min

TH4010
29,4 kW

0,6 m/min

⚡ 3~ 400V 50Hz
480V 60Hz

KVA			
EC88115VF	114	130	145
EC150218VF	136	162	189

*Dmin ■

R = 6,9 m

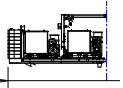

(H) ESTACIONARIA 1 / STATIONARY 1 / STATIONAIRE 1 / STATIONÄR 1 / СТАЦИОНАРНОЕ СОСТОЯНИЕ / ثابتة

TD

▽▽	H(m)	D■(m)	□	⊠
30	54,6	18	9	1
35	50,7	17	9	-
40	50,7	16	9	-
45	45,1	17	8	-
50	45,1	19	8	-
55	45,1	21	8	-
60	43,4	20	7	1
65	39,5	19	7	-

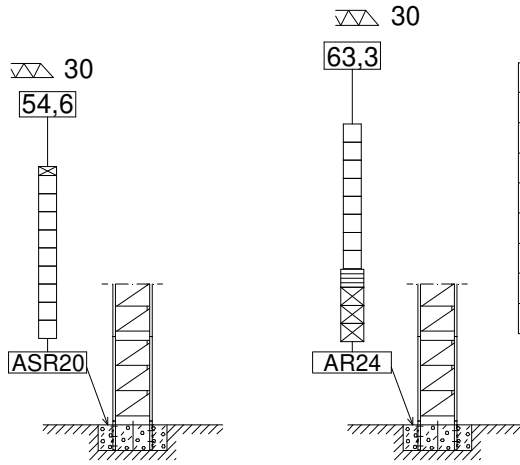

▽▽	H(m)	D■(m)	⊠	▨	□	⊠
30	63,3	18	3	1	8	-
35	61,6	17	3	1	7	1
40	57,7	16	2	1	8	-
45	57,7	17	3	1	7	-
50	56,0	19	2	1	7	1
55	52,1	21	3	1	6	-
60	52,1	20	3	1	6	-
65	46,5	19	2	1	6	-

TD / 2R / 3R

TD / 2R					
▽▽	H(m)	D■(m)	□	⊠	⊠
30	50,7	18	9	-	-
35	45,1	16	8	-	-
40	45,1	15	8	-	-
45	45,1	16	8	-	-
50	43,4	16	7	1	-
55	39,5	16	7	-	-
60	39,5	17	7	-	-
65	37,8	18	6	1	-

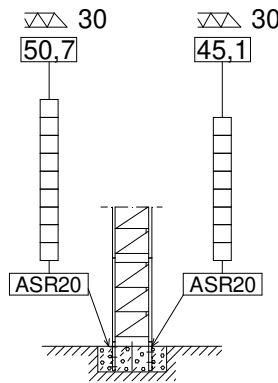

3R					
▽▽	H(m)	D■(m)	⊠	▨	⊠
30	45,1	18	8	-	-
35	39,5	16	7	-	-
40	39,5	15	7	-	-
45	39,5	16	7	-	-
50	39,5	16	7	-	-
55	39,5	16	7	-	-

TD / 2R						
▽▽	H(m)	D■(m)	⊠	▨	□	⊠
30	63,3	18	3	1	8	-
35	61,6	16	4	1	6	1
40	57,7	15	3	1	7	-
45	57,7	16	3	1	7	-
50	56,0	16	3	1	6	1
55	52,1	16	3	1	6	-
60	50,4	17	3	1	5	1
65	46,5	18	2	1	6	-

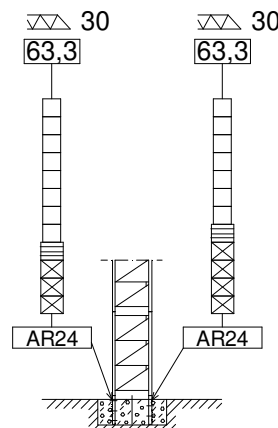

3R						
▽▽	H(m)	D■(m)	⊠	▨	□	⊠
30	63,3	18	4	1	7	-
35	61,6	16	4	1	6	1
40	57,7	15	4	1	6	-
45	56,0	16	3	1	6	1
50	52,1	16	3	1	6	-
55	52,1	16	3	1	6	-

⊠ TSR20

□ TSR20-5,6

▨ TR24/TSR20

⊠ TR24-5,6

ASR20 160.21.200

ASRD 20/24 156.21.000

AR24 156.21.200

H= Máxima altura de torre sin arriostrar (m). / Maximum tower height without fastening (m) /

Hauteur maximale de tour sans arçage (m). / Maximale Höhe ohne Verstrebung (m) / Максимальная высота башни без крепления (м). / أقصى ارتفاع للبرج بدون ربط (م)

*Dmin ■

R = 6,9 m

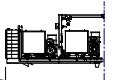

(H) ESTACIONARIA 3 / STATIONARY 3 / STATIONAIRE 3 / STATIONÄR 3 / СТАЦИОНАРНОЕ СОСТОЯНИЕ / ثابتة

TD

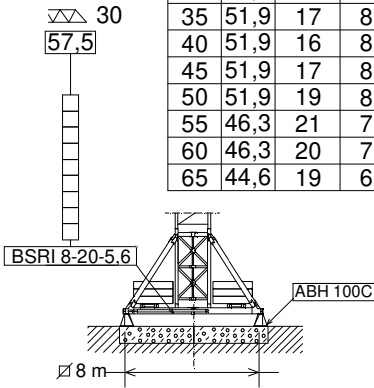

▽▽	H(m)	D■(m)	□	⊠
30	57,5	18	9	-
35	51,9	17	8	-
40	51,9	16	8	-
45	51,9	17	8	-
50	51,9	19	8	-
55	46,3	21	7	-
60	46,3	20	7	-
65	44,6	19	6	1

TD / 2R / 3R

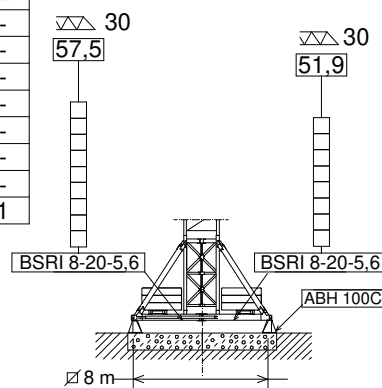

▽▽	H(m)	D■(m)	□	⊠
30	57,5	18	9	-
35	51,9	16	8	-
40	51,9	15	8	-
45	51,9	16	8	-
50	46,3	16	7	-
55	46,3	16	7	-
60	46,3	17	7	-
65	44,6	18	6	1

▽▽	H(m)	D■(m)	□	⊠
30	51,9	18	8	-
35	46,3	16	7	-
40	46,3	15	7	-
45	46,3	16	7	-
50	46,3	16	7	-
55	46,3	16	7	-

(H) TRASLACION / TRAVELLING / TRASLATION / FORTBEWEGUNG / ПЕРЕМЕЩЕНИЕ / متحركة

TD

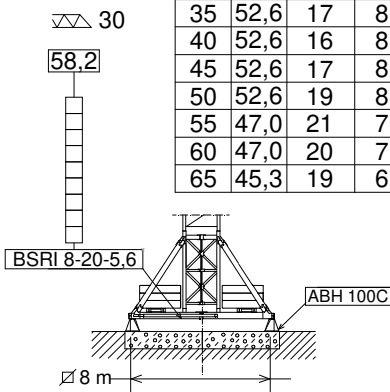

▽▽	H(m)	D■(m)	□	⊠
30	58,2	18	9	-
35	52,6	17	8	-
40	52,6	16	8	-
45	52,6	17	8	-
50	52,6	19	8	-
55	47,0	21	7	-
60	47,0	20	7	-
65	45,3	19	6	1

TD / 2R / 3R

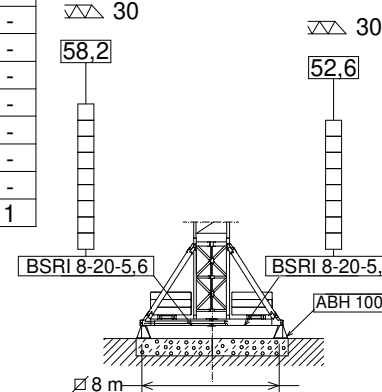

▽▽	H(m)	D■(m)	□	⊠
30	58,2	18	9	-
35	52,6	16	8	-
40	52,6	15	8	-
45	52,6	16	8	-
50	47,0	16	7	-
55	47,0	16	7	-
60	47,0	17	7	-
65	45,3	18	6	1

▽▽	H(m)	D■(m)	□	⊠
30	52,6	18	8	-
35	47,0	16	7	-
40	47,0	15	7	-
45	47,0	16	7	-
50	47,0	16	7	-
55	47,0	16	7	-

⊠ TSR20

□ TSR20-5,6

BSRI 8-20-5,6204.20.000

ABH 100C170.23.000

H= Máxima altura de torre sin arriostrar (m). / Maximum tower height without fastening (m) /

Hauteur maximale de tour sans ancrage (m). / Maximale Höhe ohne Verstreben (m) / Максимальная высота башни без крепления (м). / أقصى ارتفاع للبرج بدون ربط (م)

*Dmin ■

R = 6,9 m

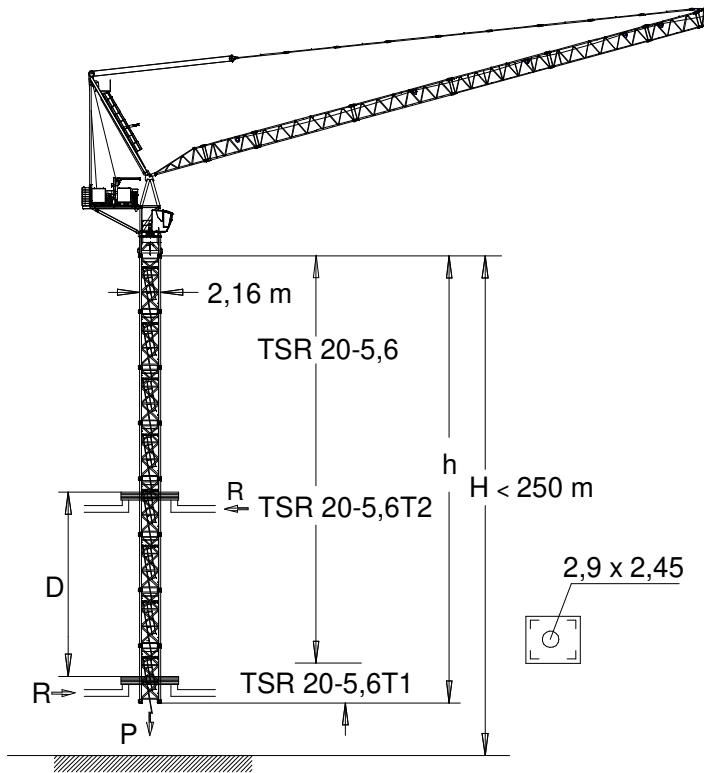
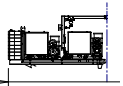

h_{max}:
TSR20-5,6T1 + 5 x TSR20-5,6 + TSR 20-5,6T2

	TD 12 t	▶	■ (D■)
h (m)	39,2		
D (m)	18 – 15		
P (KN)	1755	1755	
R _{max} (KN)	435	835	

h_{max}:
TSR20-5,6T1 + 5 x TSR20-5,6 + TSR20-5,6T2

	TD/2R/3R TD/2R 24 t	▶	■ (D■)
h (m)	39,2		
D (m)	18 – 15,6		
P (KN)	1865	1865	
R _{max} (KN)	450	820	

h_{max}:
TSR20-5,6T1 + 5 x TSR20-5,6 + TSR20-5,6T2

	TD/2R/3R 3R 36 t	▶	■ (D■)
h (m)	39,2		
D (m)	18 – 15,2		
P (KN)	1960	1600	
R _{max} (KN)	455	825	

TSR20-5,6T1: 206.31.400
TSR20-5,6T2: 206.31.500

Trepado interno / Internal climbing / Télescopage / Inneres klettersystem / Внутренняя лестница / التسلق الداخلي

R = 6,9 m

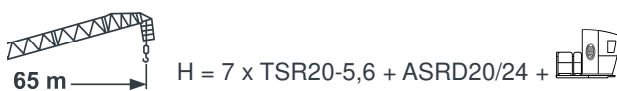
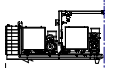

FEM 1005 - C25



Reservado el derecho a modificaciones sin previo aviso. Declinamos toda responsabilidad derivada de la información proporcionada / Subject to modification, without prior notice. This information is supplied without liability. L'entreprise se réserve le droit de procéder à des modifications sans préavis. Nous déclinons toute responsabilité quant aux informations fournies / Das Recht auf Änderungen ohne vorherige Ankündigung bleibt vorbehalten. Wir übernehmen keine Gewähr für die gemachten Angaben / Мы оставляем за собой право на внесение изменений без предварительного уведомления. Мы снимаем с себя любую ответственность отнютии предоставленной информации / حقوق التغيير محفوظة دون إشعار مسبق. دون أننى مسؤولة عن المعلومات المقدمة.

*Dmin ■

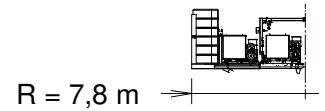

(H) ESTACIONARIA 1 / STATIONARY 1 / STATIONAIRE 1 / STATIONÄR 1 / СТАЦИОНАРНОЕ СОСТОЯНИЕ / ثابتة

TD

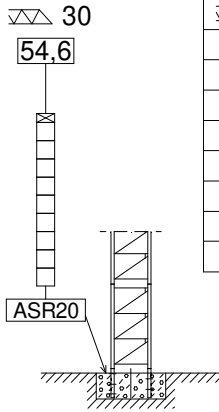

▽▽	H(m)	D■(m)	□	⊠
30	54,6	19	9	1
35	50,7	18	9	-
40	50,7	18	9	-
45	45,1	18	8	-
50	45,1	20	8	-
55	45,1	22	8	-
60	43,4	22	7	1
65	39,5	20	7	-

▽▽	H(m)	D■(m)	⊠	▨	□	⊠
30	63,3	19	3	1	8	-
35	57,7	18	2	1	8	-
40	57,7	18	3	1	7	-
45	56,0	18	2	1	7	1
50	52,1	20	2	1	7	-
55	52,1	22	3	1	6	-
60	50,4	22	3	1	5	1
65	46,5	20	2	1	6	-

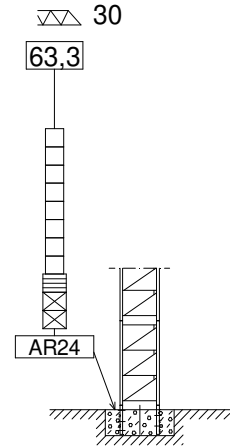

TD / 2R / 3R

TD / 2R				
▽▽	H(m)	D■(m)	□	⊠
30	49,0	20	8	1
35	45,1	18	8	-
40	45,1	17	8	-
45	45,1	17	8	-
50	43,4	17	7	1
55	39,5	17	7	-
60	37,8	17	6	1
65	37,8	18	6	1

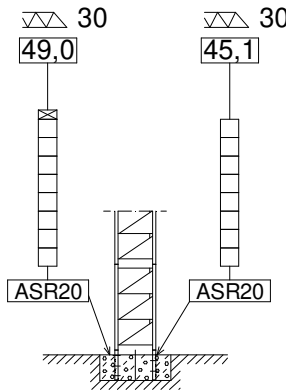

3R				
▽▽	H(m)	D■(m)	□	⊠
30	45,1	20	8	-
35	39,5	18	7	-
40	39,5	17	7	-
45	39,5	17	7	-
50	39,5	17	7	-
55	39,5	17	7	-

TD / 2R						
▽▽	H(m)	D■(m)	⊠	▨	□	⊠
30	63,3	20	3	1	8	-
35	61,6	18	4	1	6	1
40	57,7	17	3	1	7	-
45	56,0	17	3	1	6	1
50	52,1	17	2	1	7	-
55	52,1	17	3	1	6	-
60	50,4	17	3	1	5	1
65	46,5	18	2	1	6	-

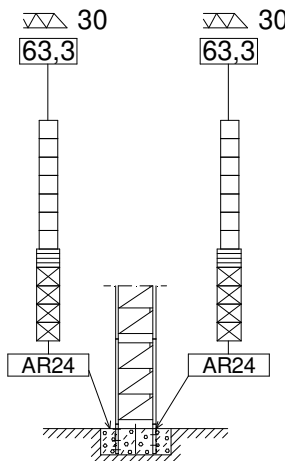

3R						
▽▽	H(m)	D■(m)	⊠	▨	□	⊠
30	63,3	20	4	1	7	-
35	61,6	18	5	1	5	1
40	57,7	17	4	1	6	-
45	56,0	17	3	1	6	1
50	52,1	17	3	1	6	-
55	52,1	17	3	1	6	-

⊠ TSR20 □ TSR20-5,6 ▨ TR24/TSR20 ⊠ TR24-5,6

ASR20 160.21.200

ASRD 20/24.....156.21.000

AR24156.21.200

H= Máxima altura de torre sin arriostrar (m). / Maximum tower height without fastening (m) /

Hauteur maximale de tour sans ancrage (m). / Maximale Höhe ohne Verstreben (m) / Максимальная высота башни без крепления (м). / أقصى ارتفاع للبرج بدون ربط (م) /



Reservado el derecho a modificaciones sin previo aviso. Declinamos toda responsabilidad derivada de la información proporcionada / Subject to modification, without prior notice. This information is supplied without liability. L'entreprise se réserve le droit de procéder à des modifications sans préavis. Nous déclinons toute responsabilité quant aux informations fournies / Das Recht auf Änderungen ohne vorherige Ankündigung bleibt vorbehalten. Wir übernehmen keine Gewähr für die gemachten Angaben / Мы оставляем за собой право на внесение изменений без предварительного уведомления. Мы снимаем с себя любую ответственность отнюдь предоставленной информации / حقوق التغيير محفوظة دون إشعار مسبق. دون أننى مسؤولية عن المعلومات المقدمة.

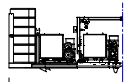

i *Dmin ■

R = 7,8 m

(H) ESTACIONARIA 3 / STATIONARY 3 / STATIONAIRE 3 / STATIONÄR 3 / СТАЦИОНАРНОЕ СОСТОЯНИЕ / ثابتة

TD

TD / 2R / 3R

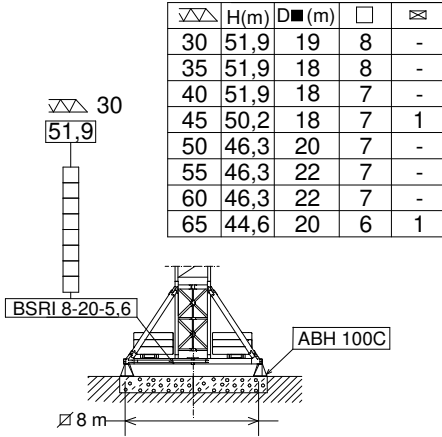

TD / 2R				
▽▽	H(m)	D■(m)	□	⊠
30	51,9	20	8	-
35	51,9	18	8	-
40	51,9	17	8	-
45	51,9	17	8	-
50	46,3	17	7	-
55	46,3	17	7	-
60	44,6	17	6	1
65	44,6	18	6	1

3R				
▽▽	H(m)	D■(m)	□	⊠
30	51,9	20	8	-
35	46,3	18	7	-
40	46,3	17	7	-
45	46,3	17	7	-
50	46,3	17	7	-
55	46,3	17	7	-

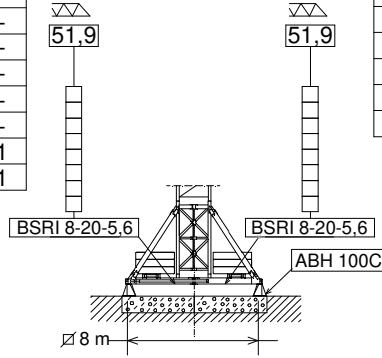

(H) TRASLACION / TRAVELLING / TRASLATION / FORTBEWEGUNG / ПЕРЕМЕЩЕНИЕ / متحركة

TD

TD / 2R / 3R

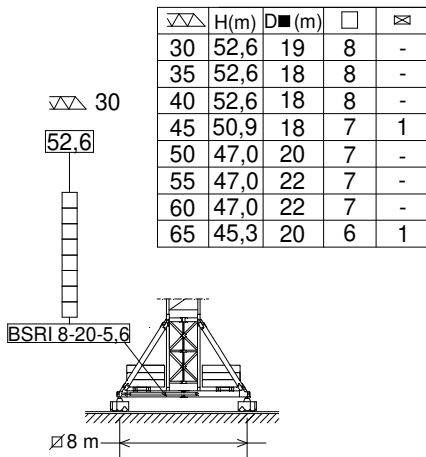

TD / 2R				
▽▽	H(m)	D■(m)	□	⊠
30	52,6	20	8	-
35	52,6	18	8	-
40	52,6	17	8	-
45	52,6	17	8	-
50	47,0	17	7	-
55	47,0	17	7	-
60	45,3	17	6	1
65	45,3	18	6	1

3R				
▽▽	H(m)	D■(m)	□	⊠
30	52,6	20	8	-
35	47,0	18	7	-
40	47,0	17	7	-
45	47,0	17	7	-
50	47,0	17	7	-
55	47,0	17	7	-

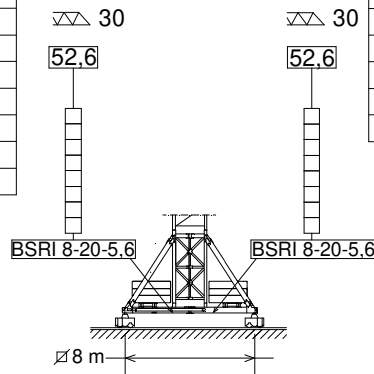

⊠ TSR20

□ TSR20-5,6

BSRI 8-20-5,6..... 204.20.000

ABH 100C..... 170.23.000

H= Máxima altura de torre sin arriostrar (m) / Maximum tower height without fastening (m) /

Hauteur maximale de tour sans ancrage (m) / Maximale Höhe ohne Verstreben (m) / Максимальная высота башни без крепления (м) / أقصى ارتفاع للبرج بدون ربط (م)

*Dmin ■

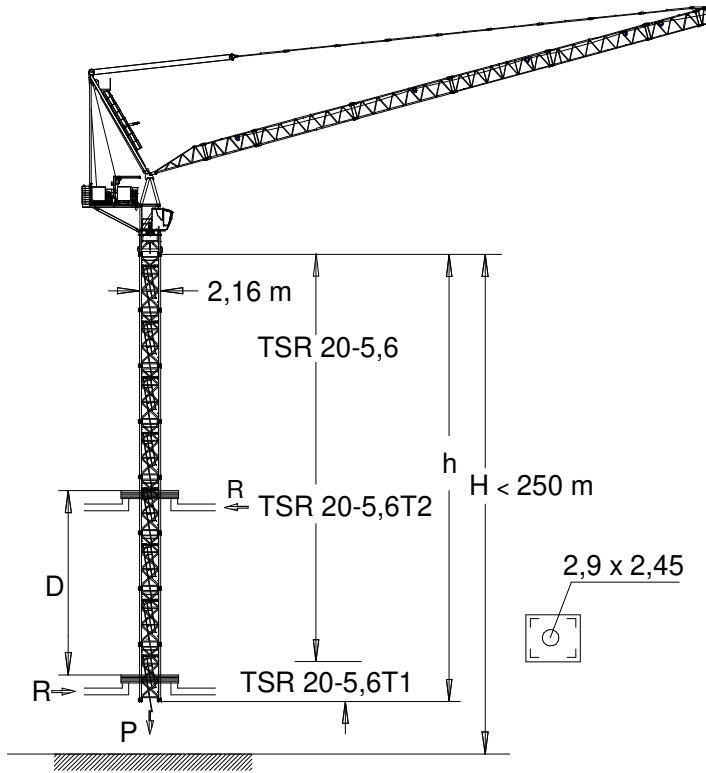
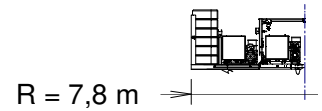

h_{max}:
TSR20-5,6T1 + 5 x TSR20-5,6 + TSR 20-5,6T2

	TD 12 t	▶	■ (D■)
h (m)	39,2		
D (m)	18 – 15,2		
P (KN)	1730	1610	
Rmax (KN)	435	835	

h_{max}:
TSR20-5,6T1 + 4 x TSR20-5,6 + TSR20-5,6T2 + TSR20

	TD/2R/3R TD/2R 24 t	▶	■ (D■)
h (m)	37,5		
D (m)	17 – 15,1		
P (KN)	1835	1595	
Rmax (KN)	460	825	

h_{max}:
TSR20-5,6T1 + 5 x TSR20-5,6 + TSR20-5,6T2

	TD/2R/3R 3R 36 t	▶	■ (D■)
h (m)	39,2		
D (m)	18 – 15,4		
P (KN)	1870	1510	
Rmax (KN)	450	820	

TSR20-5,6T1: 206.31.400
TSR20-5,6T2: 206.31.500

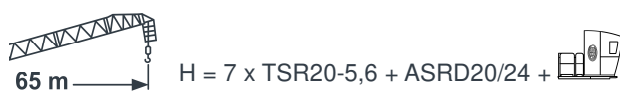
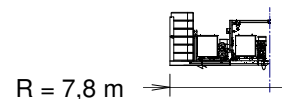

Trepado interno / Internal climbing / Téléscopage / Inneres klettersystem / Внутренняя лестница / التسلق الداخلي



FEM 1005 - C25



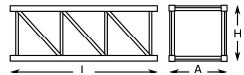
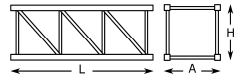
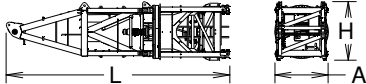
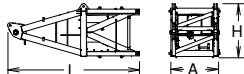
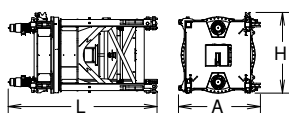
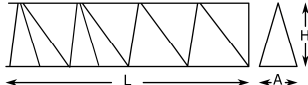
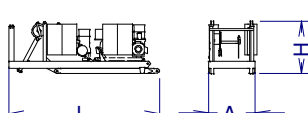

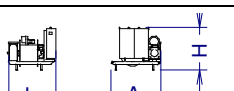
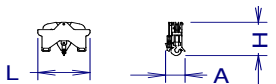
Reservado el derecho a modificaciones sin previo aviso. Declinamos toda responsabilidad derivada de la información proporcionada / Subject to modification, without prior notice. This information is supplied without liability. L'entreprise se réserve le droit de procéder à des modifications sans préavis. Nous déclinons toute responsabilité quant aux informations fournies / Das Recht auf Änderungen ohne vorherige Ankündigung bleibt vorbehalten. Wir übernehmen keine Gewähr für die gemachten Angaben / Мы оставляем за собой право на внесение изменений без предварительного уведомления. Мы снимаем с себя любую ответственность от отношении предоставленной информации / حقوق التغيير محفوظة دون إشعار مسبق. دون أننى مسؤولية عن المعلومات المقدمة.

		L (m)	A (m)	H (m)	P/W(kg)	
Torre inferior / Lower tower Tour inférieure / Unterer Turm Нижняя башня / البرج السفلى	TSRI-20-5,6		5,990	2,257	2,257	6562
Torre / Tower Tour / Turm / Башня / برج	TSR20 TSR20-5,6		4,260 5,990	2,251 2,257	2,251 2,257	3110 4210
Torre asiento pista, torre superior y orientación Slewing table, top tower and slewing mechanism Tour pivot + tour supérieure + mécanisme d'orientation Turmsitz + oberer Turm + Ausrichtung Сиденье площадки + верхняя башня + поворотный механизм برج وحدة الدوران + البرج العلوي + آلية الدوران			9,650	2,320	2,560	15825
Punta de torre / Tower head / Porte-flèche Turmspitze / верхняя секция башни / رأس البرج			5,860	2,280	2,380	5300
Torre asiento pista + base punta de torre + orientación Slewing table + tower head base + slewing mechanism Tour pivot + base du porte-flèche + mécanisme d'orientation / Turmsitz + Turmspitzenbasis + Ausrichtung Сиденье площадки + основание верхней секции башни + поворотный механизм / + قاعدة رأس البرج + آلية الدوران			4,660	2,560	2,460	10525
Tramo de pluma Jib section Tronçon de flèche Auslegerabschnitt Секция стрелы أجزاء الذراع	1 2 3 4 5 6 7 8 9-3R		6,265 10,460 10,505 10,550 10,550 10,550 5,615 3,780 2,370	2,200 1,560 1,560 1,540 1,490 1,540 1,540 1,540 1,970	1,783 1,750 1,748 1,752 1,730 1,725 1,725 1,855 3,17	1830 2710 2630 2295 1890 1745 980 995 1105
Contrapluma con mecanismos, pasteca y plumin Counterjib with mechanisms, reeving block and auxiliary jib Contre-flèche avec mécanismes et fléchette auxiliaire Gegenausleger + Mechanismus + Unterflasche + Ausleger Противовесная консоль с механизмами и вспомогательной الذراع المعاكس مع أليات وريشة مساعدة			7,300	2,241	2,495	19600
Contrapluma con elevacion pluma, pasteca y plumin Counterjib+ luffing mechanisms+ reeving block+ auxiliary jib Contre-flèche avec mécanisme de relevage de la flèche, moufle et fléchette Gegenausleger + Auslegerhebewerk + Unterflasche + Ausleger Противовесная консоль с механизмом подъема стрелы, блоком и дополнительной стрелой الذراع المعاكس مع رافع الذراع والبكرة والريشة الاضافية			7,300	2,218	2,495	12700
Mecanismo elevacion carga / Hoisting mechanism Mécanisme de levage de charge / Lasthubmechanismus Подъем груза / رافع الحمولة			2,208	2,539	2,068	6900
Polipasto / Hook assembly Palan / Flaschenzug Полиспаст / بكرة	TD/2R/3R TD		1,101 0,150	0,340 0,278	1,692 1,715	800 240

LISTA DE EMBARQUE / PACKING LIST

LISTE DE COLISAGE / KOLLI LISTE / СПИСОК ПОСТАВКИ / قائمة التحميل

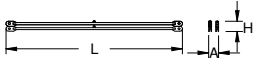
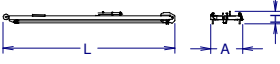
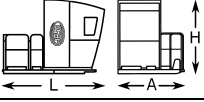
J480PA

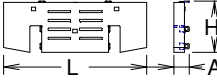
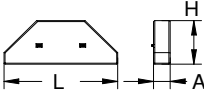
		L (m)	A (m)	H (m)	P/W(kg)
Tirante sostén pluma / Jib support tie Tirant de fleche Haltestange Ausleger Растяжка поддержки / مشد دعامة الذراع		5,850	0,430	0,615	2375
Parte superior / Top part Partie supérieure / Oberteil		11,947	2,222	0,878	6970
Plataforma y cabina / Platform and cabin Plateforme et cabine / Plattform + Führerstand Платформа и кабина / منصة وكابينة		3,670	2,300	2,480	1250
Transporte torre de montaje / Jacking cage transport Transport de tour de montage Transport Montageturm Транспортировка монтажной башни / نقل برج التركيب	TM20PASR-5,6 	10,820	2,285	2,395	12140
Contrapeso / Counterweight Contrepoids / Gegengewicht Противовес / اوزان معاكسة		2,200	0,340	0,830	3000
		4,500	0,340	0,830	6000
Contrapeso / Counterweight Contrepoids / Gegengewicht Противовес / اوزان معاكسة	Lastre / Ballast / Lest Ballast / Балласт / نقل ثقيل 	3,800	0,275	1,500	3000
		3,800	0,580	1,500	6000

 **Viento fuera de servicio / Out of service wind / Vitesse du vent hors service / Wind außer betrieb / Ветровая нагрузка в покое / الريح خارج الخدمة**

 **Consultar / Consult / Nous consulter / Anfragen / Консультируйтесь / الرجوع إلى**

 **En servicio / In service / En service / In betrieb / В работе / في الخدمة**

 **Fuera de servicio / Out of service / Hors service / Außer betrieb / В покое / خارج الخدمة**

 **Opcional / Optional / En option / Optional / Опция / اختياري**



Ctra./ Rd. Madrid – Irún - Km. 415 - 20213 IDIAZABAL (Gipuzkoa) - ESPAÑA / SPAIN

P.O. Box, 23 - 20.200 - BEASAIN - E-mail: jaso@jaso.com

Tel. +34 943 - 18 70 00 • Fax. +34 943 - 18 70 20

www.jaso.com

29/11/2024

 **FEM 1005 - C25**

DELEGACIÓN / DEALER

Reservado el derecho a modificaciones sin previo aviso. Declinamos toda responsabilidad derivada de la información proporcionada / Subject to modification, without prior notice. This information is supplied without liability / L'entreprise se réserve le droit de procéder à des modifications sans préavis. Nous déclinons toute responsabilité quant aux informations fournies / Das Recht auf Änderungen ohne vorherige Ankündigung bleibt vorbehalten. Wir übernehmen keine Gewähr für die gemachten Angaben / Мы оставляем за собой право на внесение изменений без предварительного уведомления. Мы снимаем с себя любую ответственность в отношении предоставленной информации / حقوق التغيير محفوظة دون إشعار مسبق. دون إشعار مسبق عن المعلومات المقدمة